

PUBLIC SAFETY COMPLEX SPACE NEEDS STUDY SOUTHBOROUGH, MASSACHUSETTS

**Includes:
Shared Space
Police Department
Fire Department**

THIRD DRAFT

Prepared for

**The Town of Southborough, MA
Public Safety Complex Study Committee
&
Board of Selectmen**

Prepared by

**Donham & Sweeney
ARCHITECTS**

**Jeff Shaw, Principal
Ellen Light, Project Manager**

23 November 2015

PUBLIC SAFETY COMPLEX SPACE NEEDS STUDY SOUTHBOROUGH, MASSACHUSETTS

TABLE OF CONTENTS

STAFFING:

- Police Department	4
- Fire Department	5
PARKING NEEDS SUMMARY	6
SPACE NEEDS SUMMARY	7
SHARED PROGRAM SPACE NEEDS	11
POLICE DEPARTMENT SPACE NEEDS	33
FIRE DEPARTMENT SPACE NEEDS	63

**PUBLIC SAFETY COMPLEX, SPACE NEEDS STUDY
SOUTHBOROUGH, MASSACHUSETTS**

POLICE DEPARTMENT

STAFFING PROJECTIONS

Position	Current Total	Future to 2035			Total	
		Shifts:	7 - 3	3 - 11		11 - 7
Administration						
Chief	1		1		1	
Lieutenant - Administration	0		1		1	
Lieutenant - Operations	1			1	1	
Police Business Administrator	1		1		1	
Officers						
Patrol, Sgts	4		2	2	1	5
Patrol Officers	7		5	6	5	16
Juvenile Officers/ SRO	1		1			1
Reserve Officers	2		0			0
Detectives, Sgts (Court Officer	0		1			1
Detectives	1		1	1		2
Other						
Animal Control*	0		0			0
Communications - FT	4		1	1	1	4
Communications - PT	3		0	0	0	0
TOTAL STAFF	25		14	11	7	33

*This service is contracted out.

**PUBLIC SAFETY COMPLEX, SPACE NEEDS STUDY
SOUTHBOROUGH, MASSACHUSETTS**

FIRE DEPARTMENT

STAFFING PROJECTIONS

Position	Current Total	Future to 2035		
		Business Hrs	Single Shift	Total All Shifts
Administration				
Chief	1	1		1
Deputy Chief	0	1		1
Training Officer	0	1		1
Call Safety Officer	1	0		0
Fire Prevention	1	2		2
Administrative Assistant	1	1		1
Supression				
Captains	1		1	4
Lieutenants	3		1	4
Firefighters	16		7	28
Call Firefighters	7		0	0
TOTAL STAFF	31	6	9	42

Shift Changes

Police Department

Uniformed Staff	7:00AM - 3:00PM	3:00PM - 11:00PM	11:00PM - 7:00AM
Civilion Staff	7:00AM - 3:00PM		

Fire Department

Uniformed Staff	8:00AM - 8:00AM
Civilion Staff	8:00AM - 4:00PM

**PUBLIC SAFETY COMPLEX, SPACE NEEDS STUDY
SOUTHBOROUGH, MASSACHUSETTS**

PARKING NEEDS SUMMARY

Department	Present (Day Shift)	Future (Day Shift)
Police Department		
Personal Vehicles	7	11
<i>Shift Change</i>	3	5
Cruisers	12	15
Motorcycles	1	1
Impounded Vehicles	0	2
Sub-total	23	34
Fire Department		
Personal Vehicles - Staff	4	6
Personal Vehicles - Supression	5	8
<i>Shift Change</i>	5	8
Call Vehicles	7	0
Marked Vehicles (not garaged)	3	0
Sub-total	24	22
General Public		
Public (estimate)	5	49
Total	52	105

Site Features

Flagpole	
Emergency Generator	8'x20'
Transformer	5'x5'
Trash/Recycling Enclosure	7'x12'

Emergency Management (stored outside under cover)

EM-1 Mobile Command Trailer	10'x20'
EM-2 Light Tower Trailer	4.5'x14'
EM-3 Heat Trailer	4.5'x6'
EM-4 Light Tower Trailer	4.5'x14'
EM-5 CERT/MRC (storage) Trailer	7'x14'
EM-6 Generator Trailer	5.5'x13.5'
EM-7 Message Board Trailer	8'x10'
EM-10 Shelter Storage Trailer	10'x20'
HM-1 SFD HazMat Trailer	9'x14'
CEMLEC Traffic Trailer	9'x14'
XUV on Trailer (future)	9'x14'
Forklift	8'x20'
Cold Storage:	8'x16'
Kennels	
Cones	
Sandbags	
Portable generators	
Tarps	
Construction Materials	
Tools & Protective Equipment	

**PUBLIC SAFETY COMPLEX, SPACE NEEDS STUDY
SOUTHBOROUGH, MASSACHUSETTS**

SPACE NEEDS SUMMARY

Prgm No.	Space Type Description	Needed Space Size			Tot. Needed		Floor	
		Qty	Length	Width	NASF	NASF	1st	2nd
SHARED SPACE								
1.0 Public & Other Shared Spaces								
1.1	Vestibule	1	8	8	64	64	64	
1.2	Public Lobby	1	16	20	320	320	320	
1.3	Public Toilets	2	7.5	6	45	90	90	
1.4	Public Interview Room	1	12	10	120	120	120	
1.5	Public Meeting & Training Room	1	25	40	1,000	1,000	1,000	
1.6	Public Training Storage	1	8	10	80	80	80	
1.7	Fitness Room	1	40	36	1,440	1,440		1,440
2.0 Communications								
2.1	Dispatch	1	25	30	750	750	750	
2.2	Dispatch Toilet	1	7.5	6.5	49	49	49	
2.3	Dispatch Kitchenette	1	12	8	96	96	96	
2.4	Radio / Server / E911	1	12	18	216	216	216	
3.0 Building Maintenance & Supplies								
3.1	Janitor's Closets	2	5	4	20	40	20	20
3.2	Building / Ground Equipment Storage	1	12	10	120	120	120	
4.0 Building Support								
4.1	Passenger Elevator	1	10	8	80	160	80	80
4.2	Elevator Machine Room	1	10	8	80	80	80	
4.3	Fan Rooms	1	20	30	600	600		600
4.4	Central Boiler Room	1	15	20	300	300	300	
4.5	Sprinkler / Water Service	1	6	12	72	72	72	
4.6	Data / Alarm	1	10	12	120	120	120	
4.7	Electrical Room	1	10	15	150	150	150	
4.8	Emergency Generator Transfer	1	10	8	80	80	80	
SHARED Subtotal (Net Square Footage)						5,947	3,807	2,140
Grossing Factor (walls, corridors, chases, etc.) @ 30%						1,784	1,142	642
Subtotal						7,731	4,949	2,782

**PUBLIC SAFETY COMPLEX, SPACE NEEDS STUDY
SOUTHBOROUGH, MASSACHUSETTS**

SPACE NEEDS SUMMARY

Prgm No.	Space Type Description	Needed Space Size			Tot. Needed		Floor	
		Qty	Length	Width	NASF	NASF	1st	2nd

POLICE DEPARTMENT

5.0 Administration

5.1	Police Chief's Office	1	12	16	192	192		192
5.2	Lieutenants Offices	2	12	12	144	288		288
5.3	Business Administrator	1	12	14	168	168		168
5.4	Workroom / Office Supply	1	10	9	90	90		90
5.5	Conference Room	1	14	20	280	280		280
5.6	Administrative Toilet	2	7.5	6	45	90		90

6.0 Investigations

6.1	Detectives Court Officer & Sergeant Det.	1	20	24	480	480		480
6.2	Interview Rooms	2	8	8	64	128		128
6.3	Evidence Processing	1	10	14	140	140		140
6.4	Evidence, General	1	20	20	400	400		400

7.0 Patrol

7.1	Supervising Officer	1	12	12	144	144	144	
7.2	Roll Call / Training	1	15	20	300	300	300	
7.3	Report Writing	1	6	18	108	108	108	
7.4	Patrol Sergeants	1	16	27	432	432	432	
7.5	Patrol Gear Storage	1	10	15	150	150	150	

8.0 Detention

8.1	Vehicle Sallyport	1	18	49	882	882	882	
8.2	Booking	1	18	24	432	432	432	
8.3	Storage Closet	1	2	6.5	13	13	13	
8.4	Detention Shower	1	5.5	10	55	55	55	
8.5	Holding Room (Accessible)	1	12	10	120	120	120	
8.6	Detention Cells (Accessible)	3	8	8	64	192	192	
8.7	Interview / Status Offender Room	1	8	8	64	64	64	

9.0 Support Facilities

9.1	Break Room	1	16	12	192	192	192	
9.2	Staff Toilet Rooms	2	7.5	6	49	98	98	
9.3	Men's Lockers & Showers	1	30	36	1,080	1,080		1,080
9.4	Women's Lockers & Showers	1	21	17	357	357		357
9.5	Armory	1	10	16	160	160	160	
9.6	Garage	1	14	31	434	434	434	

POLICE Subtotal (Net Square Footage)

						7,469	3,776	3,693
	Grossing Factor (walls, corridors, chases, etc.)	@	30%			2,240	1,133	1,108
	Subtotal					9,709	4,909	4,801

**PUBLIC SAFETY COMPLEX, SPACE NEEDS STUDY
SOUTHBOROUGH, MASSACHUSETTS**

SPACE NEEDS SUMMARY

Prgm No.	Space Type Description	Needed Space Size			Tot. Needed		Floor	
		Qty	Length	Width	NASF	NASF	1st	2nd
FIRE DEPARTMENT								
10.0 Administration								
10.1	Fire Chief's Office	1	15	12	180	180		180
10.2	Deputy Fire Chief's Office	1	12	12	144	144		144
10.3	Conference Room	1	12	18	216	216		216
10.4	Fire Protection & Training	1	18	20	360	360		360
10.5	EMS Office	1	10	16	160	160		160
10.6	Administrative Assistant & Waiting Area	1	12	16	192	192		192
10.7	Dead Records Storage	1	12	14	168	168		168
10.8	Captains Office	1	10	12	120	120		120
10.9	Lieutenants Office	1	12	22.5	270	270		270
11.0 Apparatus and Support								
11.1	Apparatus Room	1	92	90	8,280	8,280	8,280	
11.2	Turn-out Gear	1	18	26	468	468	468	
11.3	Hose & Foam Storage	1	10	10	100	100	100	
11.4	Biohazard / Decon Room	1	10	8	80	80	80	
11.5	EMS Supplies	1	9	20	180	180	180	
11.6	Gear Supply	1	9	16	144	144	144	
11.7	Air Supply	1	10	10	100	100	100	
11.8	Extractor & Dryer (Contaminated)	1	8	14	112	112	112	
11.9	Triage Room	1	10	8	80	80	80	
11.10	Firefighter Toilet	1	6	6	36	36	36	
11.11	Fire Pole	1	4	8	32	32	32	
11.12	Watch Room	1	8	8	64	64	64	
11.13	Equipment Repair	1	10	14	140	140	140	
11.14	"SAFE" Program Storage	1	10	10	100	100	100	
11.15	Emergency Management Storage	1	10	15	150	150		150
12.0 Firefighter Quarters								
12.1	Kitchen	1	18	20	360	360		360
12.2	Day & Dining Room	1	24	20	480	480		480
12.3	Men's Showers	1	13	15	195	195		195
12.4	Women's Showers	1	9	6.5	59	59		59
12.5	Firefighter Dorm Rooms	8	13	10	130	1,040		1,040
12.6	Study	1	10	14	140	140		140
12.7	Washer / Dryer	1	3	6	18	18		18
12.8	Storage & Supplies	1	10	7	70	70		70
13.0 Training								
13.1	Training Stair/Tower	1	14	20	280	280	280	
FIRE DEPARTMENT Subtotal (Net Square Footage)						14,518	10,196	4,322
Grossing Factor (walls, corridors, chases, etc.) @ 30%						4,355	3,059	1,297
Subtotal						18,873	13,255	5,619
GRAND TOTAL SQUARE FOOTAGE						36,312	23,113	13,202

Donham & Sweeney
ARCHITECTS
68 Harrison Ave
Boston, MA 02111
617 - 423 - 1400

SHARED PROGRAM SPACE NEEDS

PROGRAM SHARED BY:
POLICE DEPARTMENT
FIRE DEPARTMENT

**PUBLIC SAFETY COMPLEX, SPACE NEEDS STUDY
SOUTHBOROUGH, MASSACHUSETTS**

SHARED SPACE

1.1 VESTIBULE

Adjacency Requirement	Adjacent to Public Lobby & Exterior
Public Access	High
Security Requirements	Moderate
Contract Millwork / Equipment	None
Floor	Epoxy terrazzo, stone or other durable material
Walls	GWB, painted & glazing
Ceiling	GWB, painted
Lighting / Electrical	Bright, direct
HVAC / Plumbing	A/C
Special Needs	Walk-off mat (Roll-out)
Owner supplied Furn. / Equip.	None

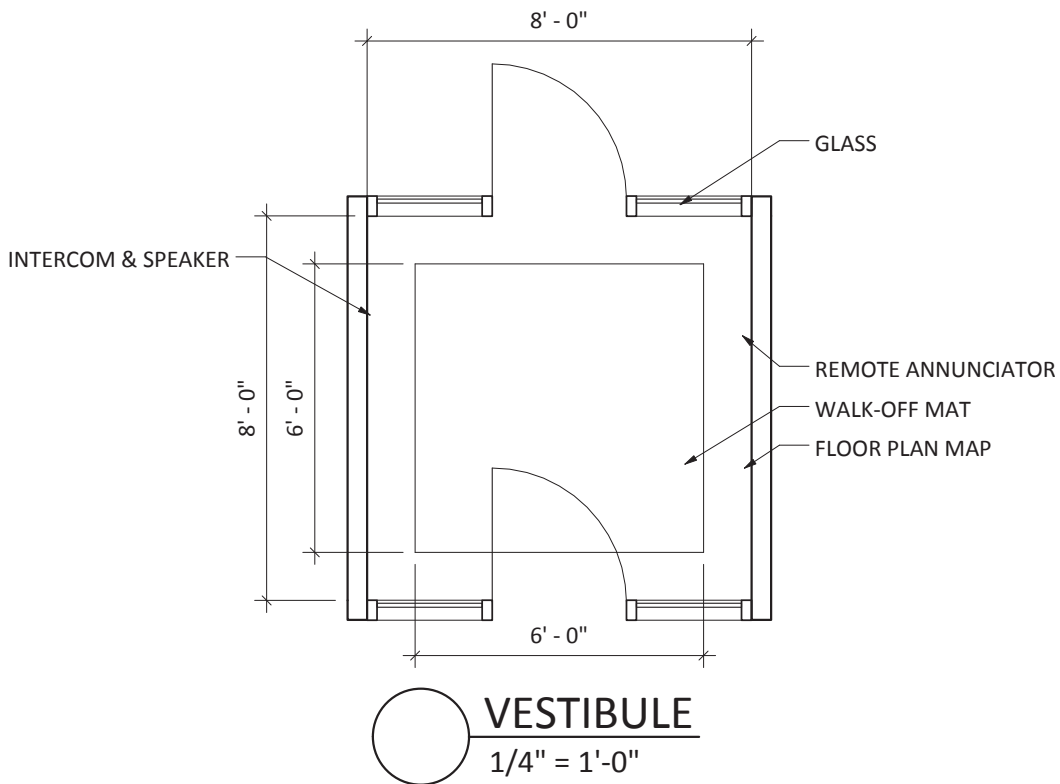

**PUBLIC SAFETY COMPLEX, SPACE NEEDS STUDY
SOUTHBOROUGH, MASSACHUSETTS**

SHARED SPACE

1.2 PUBLIC LOBBY

Adjacency Requirement	Adjacent to Public Meeting and Training Room, Dispatch, Public Interview Room, Public Toilets. Easy access but not visible to Administration.
Public Access	High
Security Requirements	Moderate; controlled exit from lobby to the rest of the building. Secure space requires electrical release into adjacent spaces.
Contract Millwork / Equipment	Tack board for public notices, large pamphlet rack, wood wainscoting, transaction counter (ADA height), 10' of glass enclosed display cases for historical artifacts (both Police & Fire)
Floor	Epoxy, terrazzo or stone tile
Walls	GWB, painted, bullet resistant board
Ceiling	ACT upgrade, bullet resistant board (soffits at walls)
Lighting / Electrical	Bright indirect; accent lighting; public phone; CCTV
HVAC / Plumbing	A/C; two level drinking fountain
Special Needs	Good visibility from Dispatch. Durable finishes. Walls and ceilings to be bullet resistant. Elevator control from Dispatch.
Owner supplied Furn. / Equip.	Seating for 4

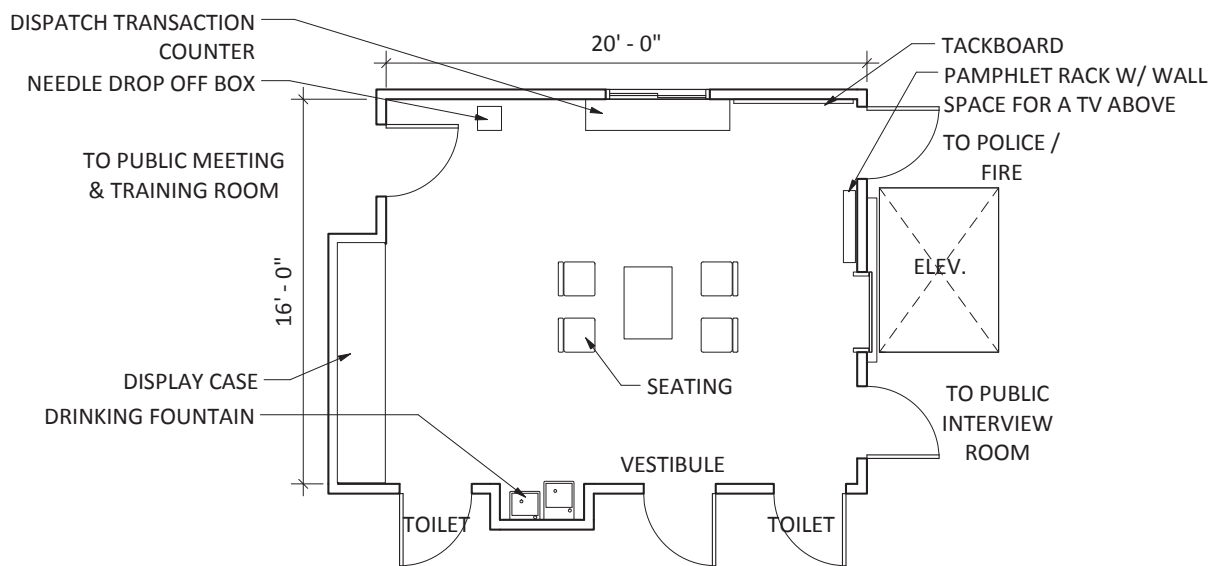

PUBLIC LOBBY
1/8" = 1'-0"

Donham & Sweeney
ARCHITECTS
68 Harrison Ave
Boston, MA 02111
617 - 423 - 1400

**PUBLIC SAFETY COMPLEX, SPACE NEEDS STUDY
SOUTHBOROUGH, MASSACHUSETTS**

SHARED SPACE

1.3 PUBLIC TOILETS

Adjacency Requirement	Public Toilets off the Public Lobby; (1) Woman's & (1) Men's.
Public Access	High
Security Requirements	Privacy, lock able to be released from lobby.
Contract Millwork / Equipment	Bathroom accessories, changing table
Floor	Ceramic tile
Walls	Ceramic tile wainscot, all four walls.
Ceiling	ACT
Lighting / Electrical	LED on sensor
HVAC / Plumbing	Good exhaust; wall mounted toilet, & sink.
Special Needs	Handicap accessible
Owner supplied Furn. / Equip.	None

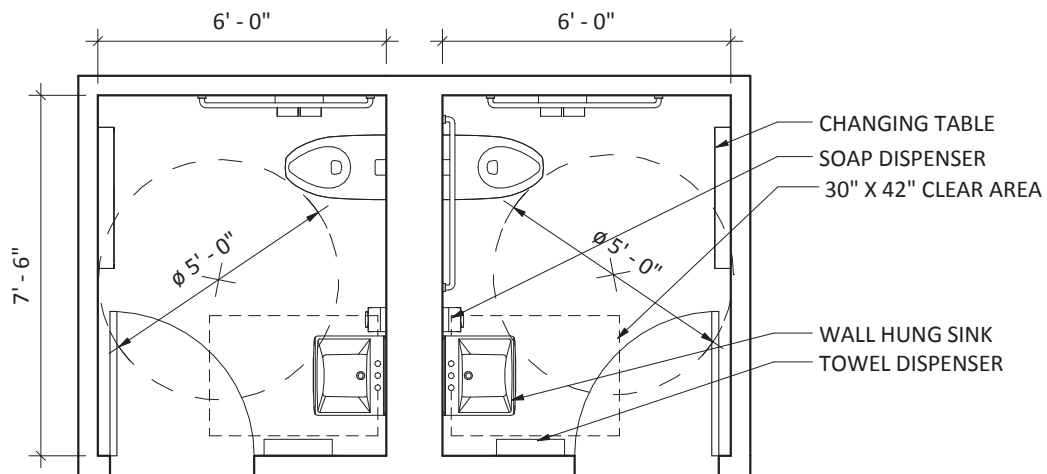

PUBLIC TOILETS
1/4" = 1'-0"

**PUBLIC SAFETY COMPLEX, SPACE NEEDS STUDY
SOUTHBOROUGH, MASSACHUSETTS**

SHARED SPACE

1.4 PUBLIC INTERVIEW

Adjacency Requirement	Access from Lobby & from secure side.
Public Access	High
Security Requirements	Door visible from Front Desk
Contract Millwork / Equipment	Chair rail, work counter w/ shelving above
Floor	Linoleum w/ area rug
Walls	GWB, painted
Ceiling	ACT
Lighting / Electrical	Indirect LED; pleasant, not glaring, intercom to Dispatch; CCTV
HVAC / Plumbing	A/C
Special Needs	None
Owner supplied Furn. / Equip.	3'x 4' table, (5) chairs

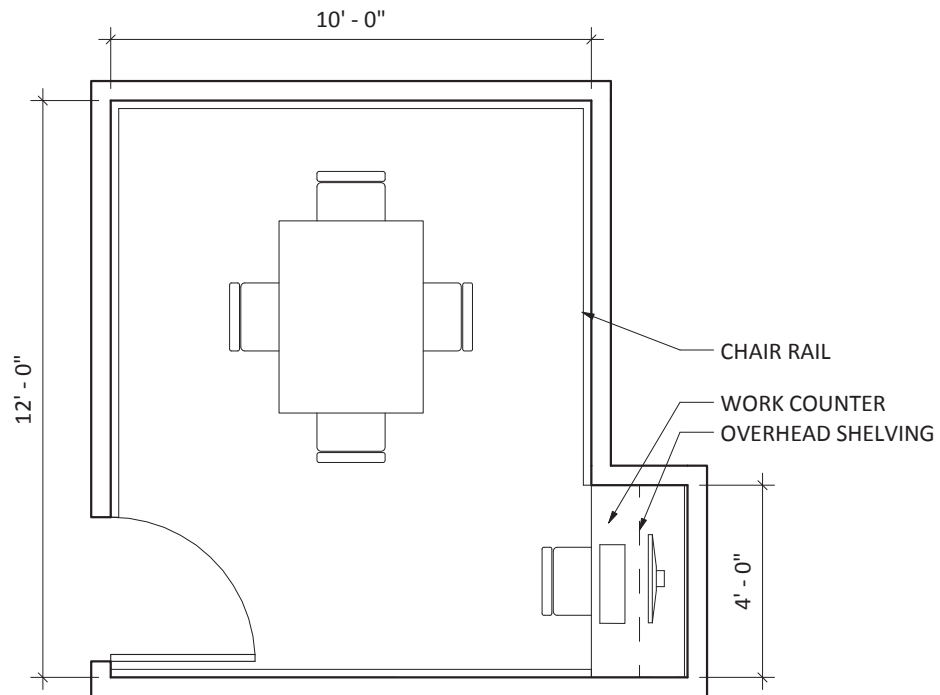

 **PUBLIC INTERVIEW ROOM**
1/4" = 1'-0"

**PUBLIC SAFETY COMPLEX, SPACE NEEDS STUDY
SOUTHBOROUGH, MASSACHUSETTS**

SHARED SPACE

1.5 PUBLIC MEETING & TRAINING ROOM

Adjacency Requirement	Easily accessible from Lobby. Near Fire Dept. Kitchen. Adjacent to Storage Closet
Public Access	Moderate
Security Requirements	Moderate; Card Key Access; Access from Dispatch
Contract Millwork / Equipment	Fabric covered tackable surfaces; coat rod & shelf. Coffee counter w/ sink.
Floor	Carpet tile
Walls	GWB, painted w/ chair rail
Ceiling	ACT upgrade
Lighting / Electrical	Numerous power & wireless data outlets. Indirect LED, glare free, dimmable. Speaker system, power outlets under each table. Wireless data system. CATV
HVAC / Plumbing	A/C w/ good exhaust system
Special Needs	Pull out divider wall; Ability to telecast from the space. Space to be adaptable for use as the Emergency Operation Center (EOC). Meals to be served to space from Fire Dept Kitchen. EOC Closet (for phones)
Owner supplied Furn. / Equip.	(24) 5' long training tables w/ seating for (49) people, podium, 2 smart board, motorized projection screen, projector, & 2 TV's - position for viewing when room divided.

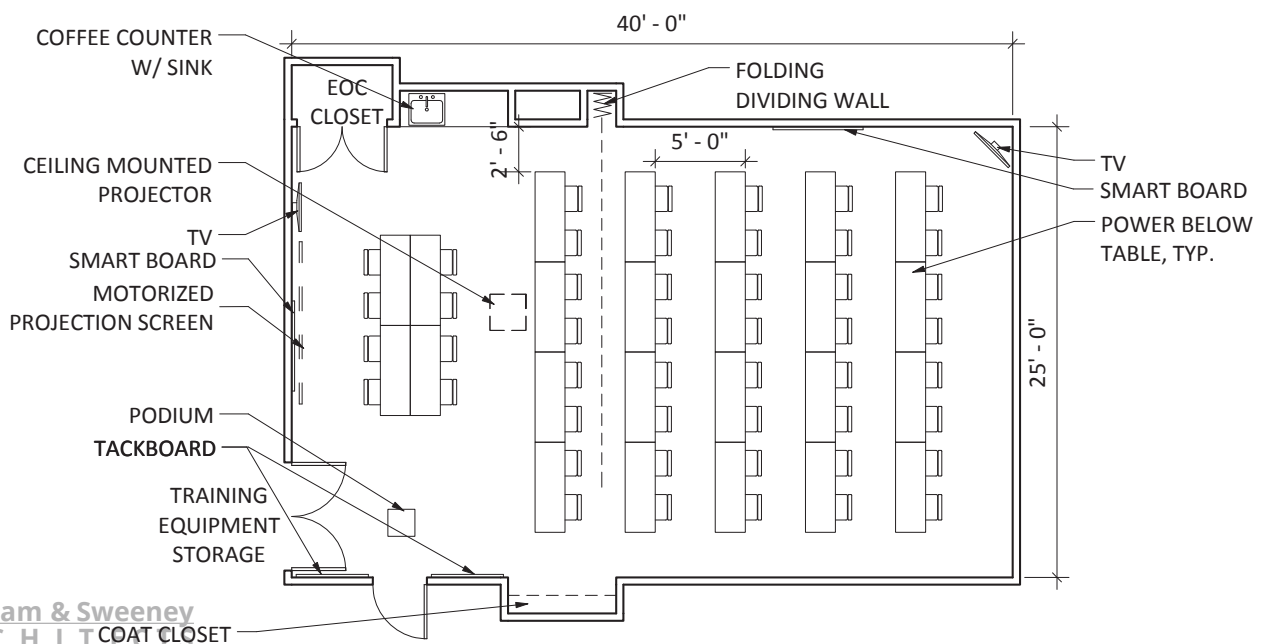

Donham & Sweeney
ARCHITECTS
68 Harrison Ave
Boston, MA 02111
617 - 423 - 1400

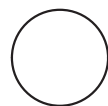

PUBLIC MEETING & TRAINING ROOM
3/32" = 1'-0"

11/23/2015

**PUBLIC SAFETY COMPLEX, SPACE NEEDS STUDY
SOUTHBOROUGH, MASSACHUSETTS**

SHARED SPACE

1.6 PUBLIC TRAINING STORAGE

Adjacency Requirement	Off Public Meeting & Training Room.
Public Access	None
Security Requirements	Moderate
Contract Millwork / Equipment	18" deep metal shelving on one wall
Floor	Rubber or Linoleum
Walls	GWB, painted
Ceiling	ACT
Lighting / Electrical	LED
HVAC / Plumbing	No A/C
Special Needs	Storage for 50% of tables and chairs (stacked on carts), training mannequins & training equipment
Owner supplied Furn. / Equip.	None

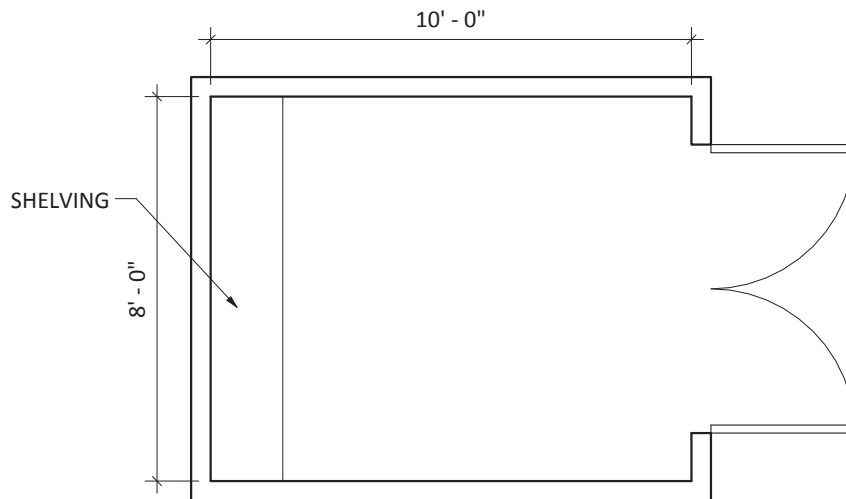

○ PUBLIC TRAINING STORAGE
1/4" = 1'-0"

**PUBLIC SAFETY COMPLEX, SPACE NEEDS STUDY
SOUTHBOROUGH, MASSACHUSETTS**

SHARED SPACE

1.7 FITNESS ROOM

Adjacency Requirement	Exterior access for Town Staff. Good internal access to Police & Fire. Adjacent to Fitness Shower Room
Public Access	Use by all building employees and Town Staff. Key card access.
Security Requirements	High
Contract Millwork / Equipment	12" metal wall shelving in storage closet
Floor	Resilient or rubber sports flooring.
Walls	GWB / CMU, painted, 4 - 3'x6' wall mirrors
Ceiling	GWB
Lighting / Electrical	LED; CATV for wall mounted TV, ceiling speakers; emergency button on (3) walls
HVAC / Plumbing	Good ventilation
Special Needs	Used by 6 people at once. Include storage closet
Owner supplied Furn. / Equip.	(2) treadmills, (2) stair stepers, (2) elliptical, (2) stationary bikes, 2) weight benches, (1) universal, (1) smith machine, (1) heavy bag, (3) flat panel TVs, sanitary wipe dispenser, mats for floor exercise area, weight racks.

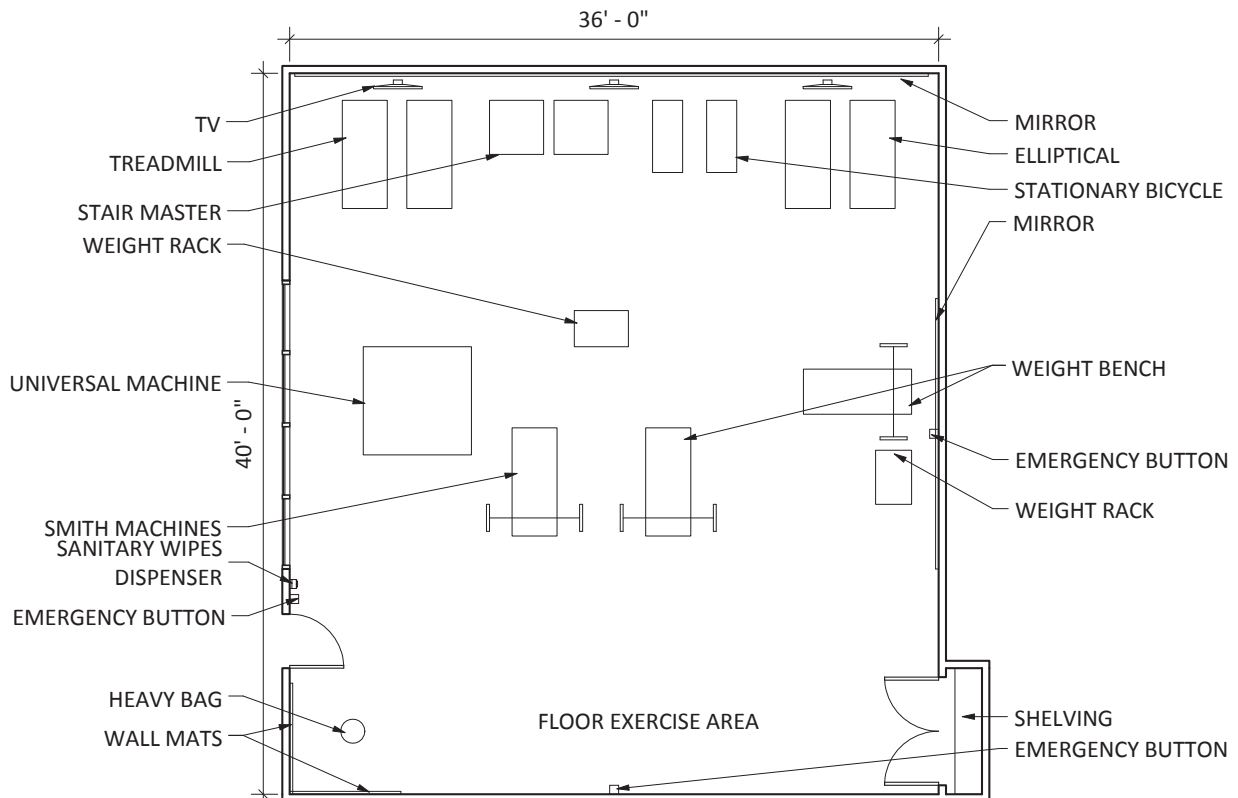

**PUBLIC SAFETY COMPLEX, SPACE NEEDS STUDY
SOUTHBOROUGH, MASSACHUSETTS**

SHARED SPACE

2.1 DISPATCH

Adjacency Requirement	Overlooks Lobby, Near Supervising Officer, centrally located. Dispatchers Toilet & Break Room adjacent. Near E911 Room (vertically)
Public Access	None
Security Requirements	Very high
Millwork	16 LF fabric covered tack panels, work counter
Floor	Low static Carpet tiles on raised access flooring
Walls	GWB, painted, sound absorbing panels
Ceiling	ACT w/ high NRC
Lighting / Electrical	Indirect LED, (2) levels lighting, task lighting, controls for alarm or zetron; (5) large screen 4'x 6' CCTV monitors, CATV
HVAC / Plumbing	A/C on emergency generator
Special Needs	Printers, copier, fax; electric release and intercom for vehicle sallyport. Electric door release for cell doors
Furniture / Equipment	(2) dispatch console positions w/ rear access, (2) high-intensity use chairs, (2) pedestal files, multi-function printer, printer. Provide space for 3rd complete position (future)

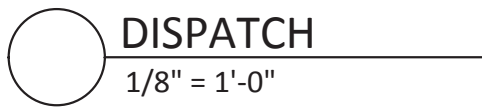
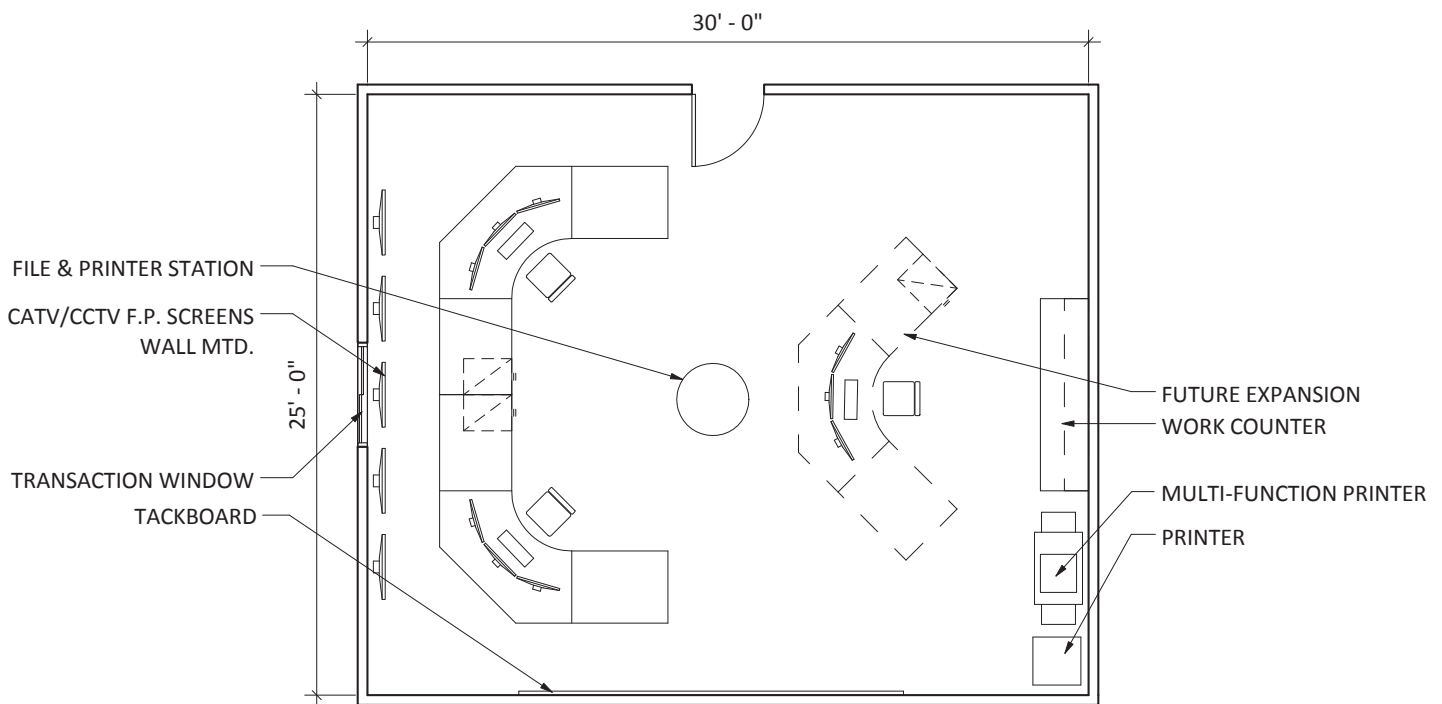

**PUBLIC SAFETY COMPLEX, SPACE NEEDS STUDY
SOUTHBOROUGH, MASSACHUSETTS**

SHARED SPACE

2.2 DISPATCH TOILET

Adjacency Requirement	Directly next to Dispatch, close to Dispatch Break Room
Public Access	None
Security Requirements	High
Millwork	None
Floor	Ceramic tile
Walls	Ceramic tile wainscot, all walls
Ceiling	ACT
Lighting / Electrical	LED
HVAC / Plumbing	Good exhaust; (1) toilet and (1) sink
Special Needs	Handicap accessible, locate a telephone near toilet
Furniture / Equipment	None

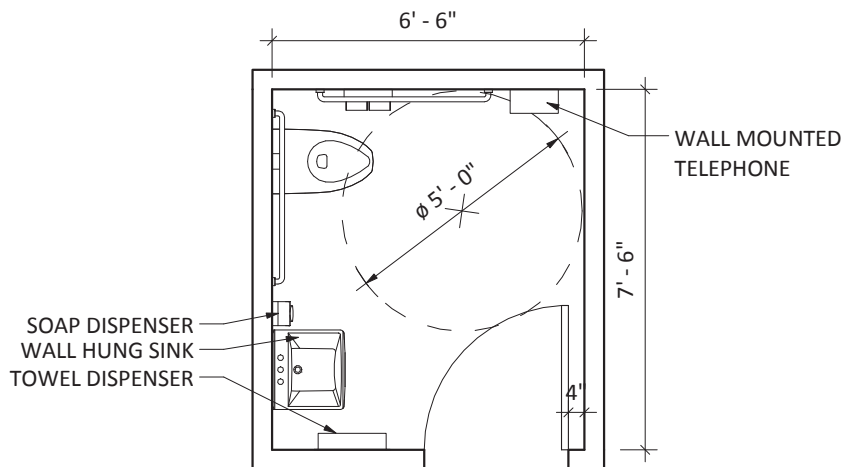

○ DISPATCH TOILET
1/4" = 1'-0"

**PUBLIC SAFETY COMPLEX, SPACE NEEDS STUDY
SOUTHBOROUGH, MASSACHUSETTS**

SHARED SPACE

2.3 DISPATCH KITCHENETTE

Adjacency Requirement	Access from Dispatch
Public Access	None
Security Requirements	High
Contract Millwork / Equipment	24" Base and wall cabinets; (12) 24"Dx12"W half height metal lockers
Floor	Rubber or Linoleum
Walls	GWB, painted
Ceiling	ACT
Lighting / Electrical	LED w/ sensor
HVAC / Plumbing	A/C; sink
Special Needs	None
Owner supplied Furn. / Equip.	Small round table w/ 2 chairs, microwave, coffee maker, undercounter refrigerator

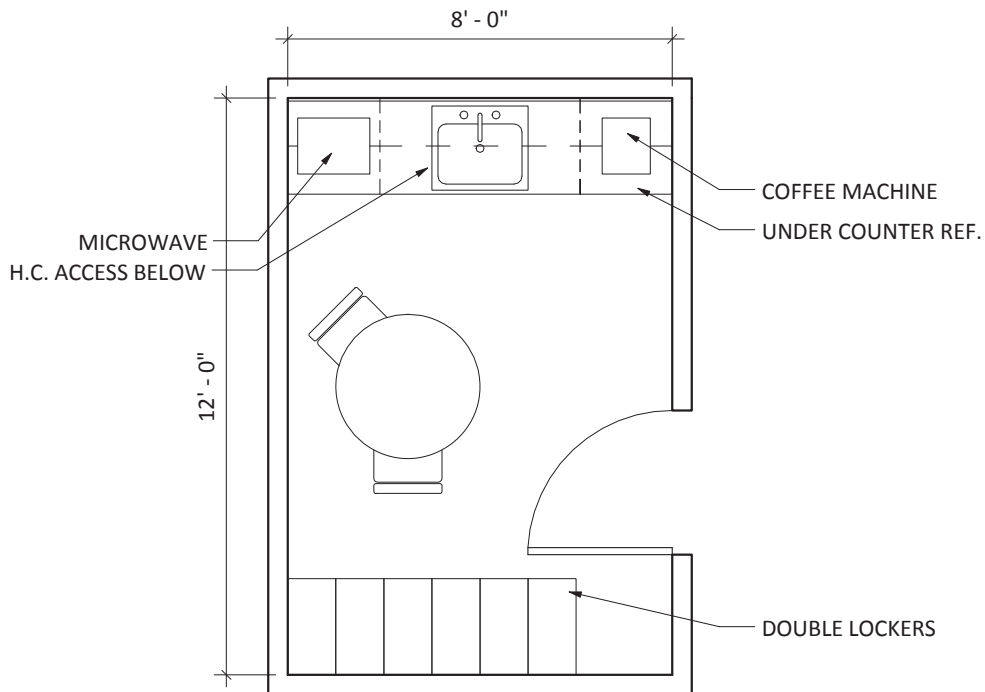

DISPATCH KITCHENETTE
1/4" = 1'-0"

**PUBLIC SAFETY COMPLEX, SPACE NEEDS STUDY
SOUTHBOROUGH, MASSACHUSETTS**

SHARED SPACE

2.4 RADIO/SERVER/E911

Adjacency Requirement	Centrally located; Accessible from either Department
Public Access	Controlled (Vendors)
Security Requirements	High
Contract Millwork / Equipment	Painted FR plywood on 2x4 sleepers along all walls
Floor	Rubber or Linoleum
Walls	GWB, painted
Ceiling	None
Lighting / Electrical	Utility. O.H. cable trays.
HVAC / Plumbing	Independant A/C
Special Needs	Door to be alarmed.
Owner supplied Furn. / Equip.	(5) computer racks, E911 rack/area, VOIP telephone. UPS & battery backup.

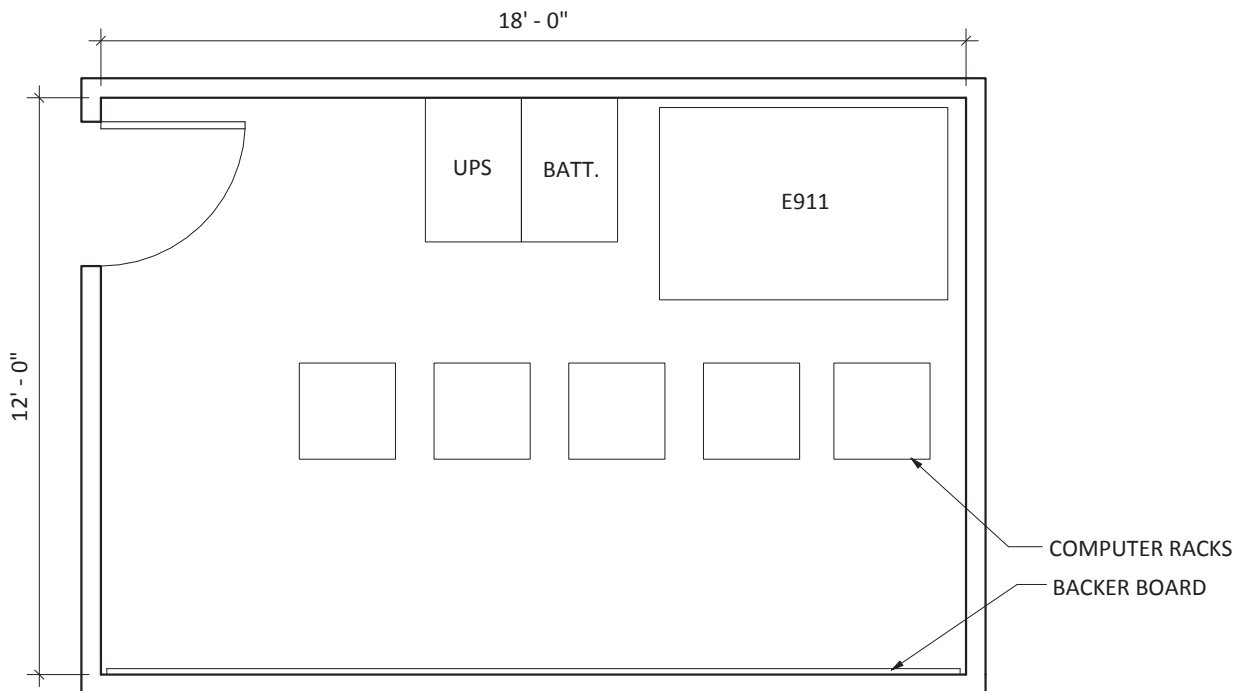

 **RADIO / SERVER / E911**
1/4" = 1'-0"

**PUBLIC SAFETY COMPLEX, SPACE NEEDS STUDY
SOUTHBOROUGH, MASSACHUSETTS**

SHARED SPACE

3.1 JANITOR'S CLOSET

Adjacency Requirement	Good access to elevator. Centrally located on each floor.
Public Access	None
Security Requirements	Low
Contract Millwork / Equipment	Mop holder w/metal shelf along one wall above sink basin, stainless steel splash guards on walls at sink.
Floor	Rubber
Walls	FRP (full height)
Ceiling	ACT
Lighting / Electrical	LED, Utility
HVAC / Plumbing	Exhaust only. Floor sink & wall faucet. Spray head & 6' hose.
Special Needs	None
Owner supplied Furn. / Equip.	Janitor cart

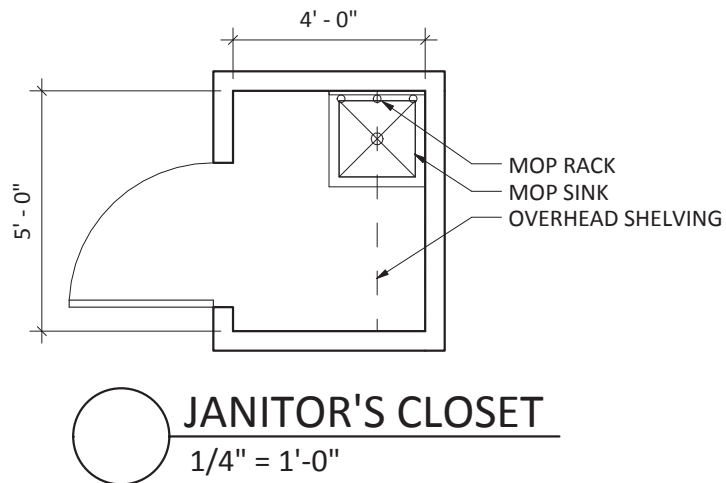

**PUBLIC SAFETY COMPLEX, SPACE NEEDS STUDY
SOUTHBOROUGH, MASSACHUSETTS**

SHARED SPACE

3.2 BUILDING / GROUNDS EQUIPMENT STORAGE

Adjacency Requirement	Exterior access only
Public Access	None
Security Requirements	Low
Contract Millwork / Equipment	24" high density shelving
Floor	Concrete w/ hardener
Walls	CMU / FRP on GWB
Ceiling	None; painted exposed structure
Lighting / Electrical	Utility
HVAC / Plumbing	No A/C, good ventilation; vent for flammables cabinet
Special Needs	Storage for snow blowers, shovels, leaf blower, de-icer, B&G equipment, etc.
Owner supplied Furn. / Equip.	Flammable materials cabinet (fluid storage)

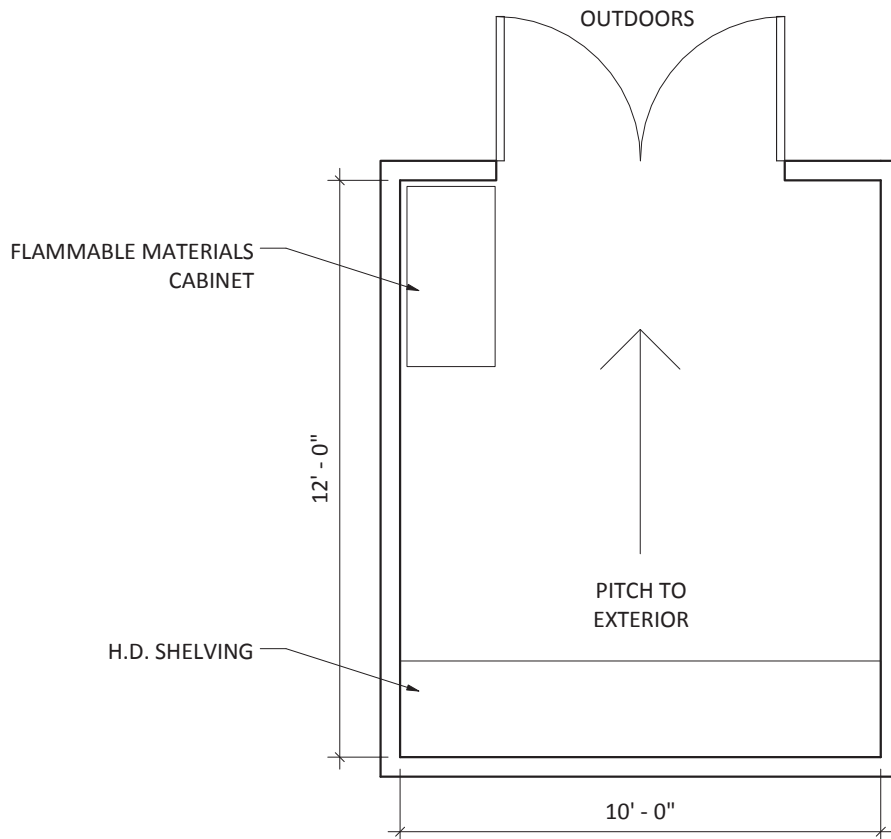

BUILDING / GROUNDS EQUIPMENT STORAGE

1/4" = 1'-0"

**PUBLIC SAFETY COMPLEX, SPACE NEEDS STUDY
SOUTHBOROUGH, MASSACHUSETTS**

SHARED SPACE

4.1 PASSENGER ELEVATOR

Adjacency Requirement	Adjacent to Public Lobby
Public Access	High
Security Requirements	Moderate
Contract Millwork / Equipment	None
Floor	Same as Public Lobby
Walls	CMU shaft wall
Ceiling	None
Lighting / Electrical	LED
HVAC / Plumbing	No A/C
Special Needs	Elevator shall be sized for stretcher. Cab walls to be plastic laminate
Owner supplied Furn. / Equip.	None

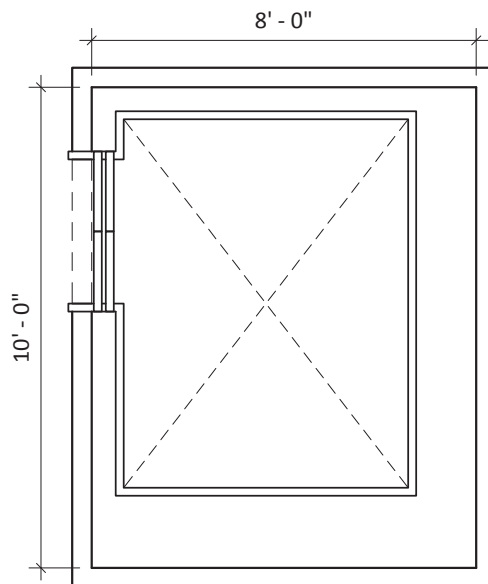

 **PASSENGER ELEVATOR**
1/4" = 1'-0"

**PUBLIC SAFETY COMPLEX, SPACE NEEDS STUDY
SOUTHBOROUGH, MASSACHUSETTS**

SHARED SPACE

4.2 ELEVATOR MACHINE ROOM

Adjacency Requirement	Adjacent to Elevator
Public Access	None
Security Requirements	Moderate
Contract Millwork / Equipment	None
Floor	Concrete w/ hardener
Walls	GWB, painted
Ceiling	None
Lighting / Electrical	LED, utility
HVAC / Plumbing	A/C (hydraulic elevator)
Special Needs	None
Owner supplied Furn. / Equip.	None

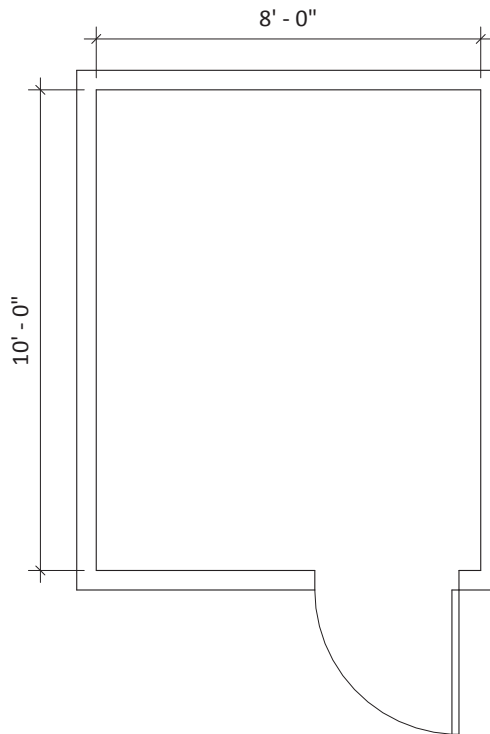

 **ELEVATOR MACHINE ROOM**
1/4" = 1'-0"

**PUBLIC SAFETY COMPLEX, SPACE NEEDS STUDY
SOUTHBOROUGH, MASSACHUSETTS**

SHARED SPACE

4.3 FAN ROOM

Adjacency Requirement

Public Access	None
Security Requirements	Moderate
Contract Millwork / Equipment	None
Floor	Concrete w/ hardener
Walls	GWB, painted
Ceiling	None
Lighting / Electrical	LED, utility
HVAC / Plumbing	Exhaust only
Special Needs	None
Owner supplied Furn. / Equip.	None

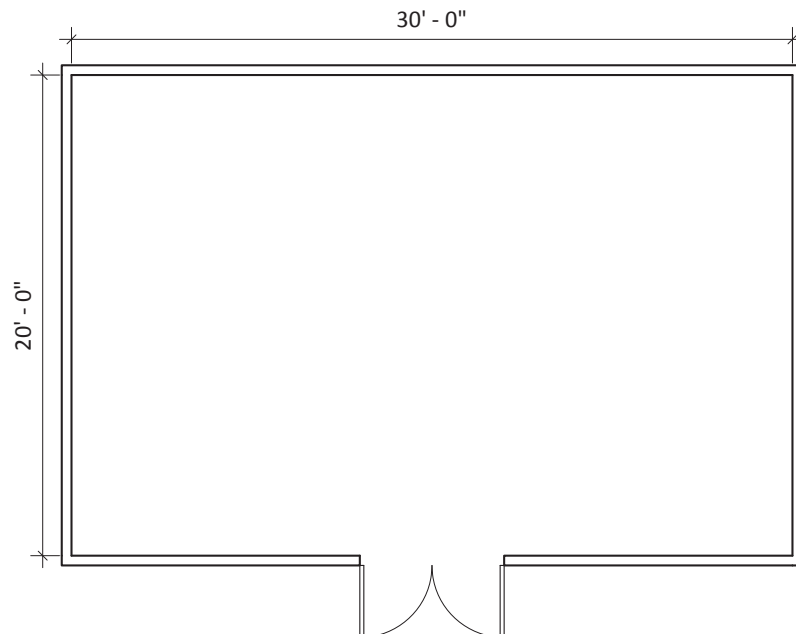

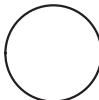
 **FAN ROOM**
1/8" = 1'-0"

**PUBLIC SAFETY COMPLEX, SPACE NEEDS STUDY
SOUTHBOROUGH, MASSACHUSETTS**

SHARED SPACE

4.4 CENTRAL BOILER ROOM

Adjacency Requirement

Public Access	None
Security Requirements	Moderate
Contract Millwork / Equipment	None
Floor	Concrete w/ hardener
Walls	GWB, painted
Ceiling	None
Lighting / Electrical	LED, utility. Power required for equipment
HVAC / Plumbing	Plumbing required for equipment
Special Needs	None
Owner supplied Furn. / Equip.	None

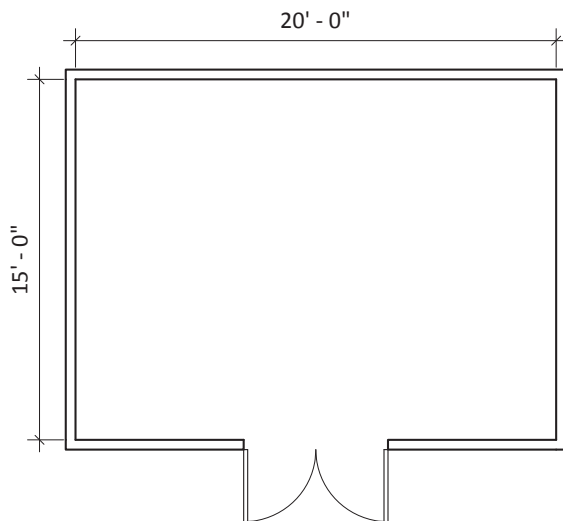

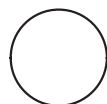
 **CENTRAL BOILER ROOM**
1/8" = 1'-0"

**PUBLIC SAFETY COMPLEX, SPACE NEEDS STUDY
SOUTHBOROUGH, MASSACHUSETTS**

SHARED SPACE

4.5 SPRINKLER / WATER SERVICE

Adjacency Requirement

Public Access	None
Security Requirements	Moderate
Contract Millwork / Equipment	None
Floor	Concrete w/ hardener
Walls	GWB, painted
Ceiling	None
Lighting / Electrical	LED, utility. Power required for equipment
HVAC / Plumbing	Plumbing required for equipment
Special Needs	None
Owner supplied Furn. / Equip.	None

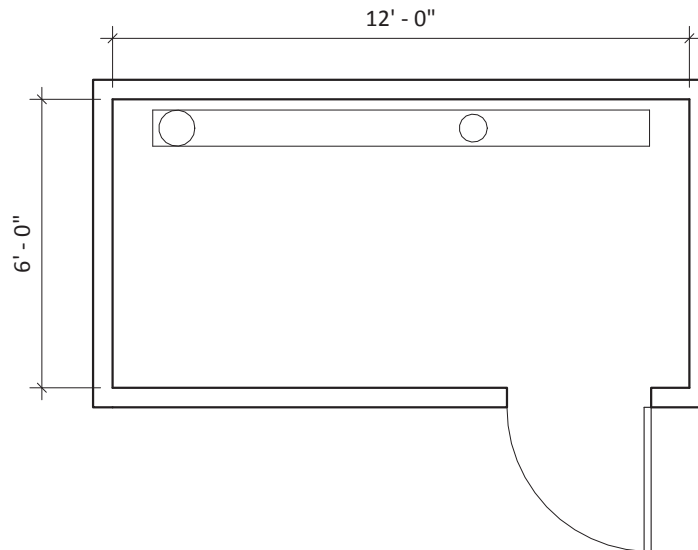

 **SPRINKLER / WATER SERVICE**
1/4" = 1'-0"

**PUBLIC SAFETY COMPLEX, SPACE NEEDS STUDY
SOUTHBOROUGH, MASSACHUSETTS**

SHARED SPACE

4.6 DATA / ALARM

Adjacency Requirement

Public Access	None
Security Requirements	High
Contract Millwork / Equipment	None
Floor	Concrete w/ hardener
Walls	GWB, painted
Ceiling	None
Lighting / Electrical	LED, utility. Power required for equipment
HVAC / Plumbing	A/C
Special Needs	None
Owner supplied Furn. / Equip.	None

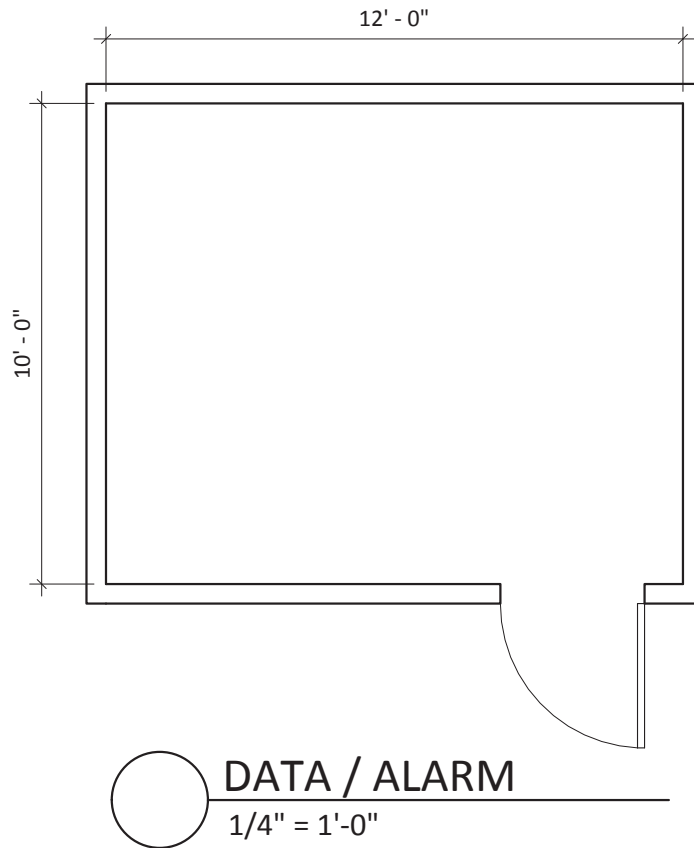

**PUBLIC SAFETY COMPLEX, SPACE NEEDS STUDY
SOUTHBOROUGH, MASSACHUSETTS**

SHARED SPACE

4.7 ELECTRICAL ROOM

Adjacency Requirement

Public Access None

Security Requirements Moderate

Contract Millwork / Equipment None

Floor Concrete w/ hardener

Walls GWB, painted

Ceiling None

Lighting / Electrical LED, utility

HVAC / Plumbing None

Special Needs Painted 3/4" plywood panels mounted to walls for mounting of electrical equipment

Owner supplied Furn. / Equip. None

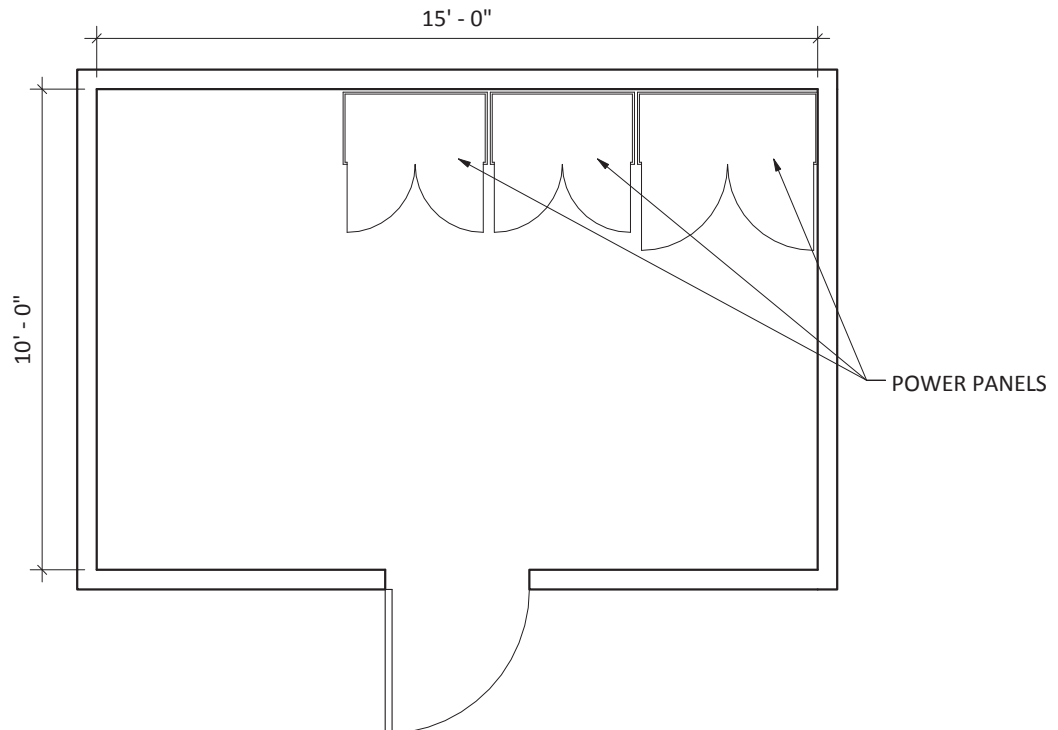

 **ELECTRICAL ROOM**
1/4" = 1'-0"

**PUBLIC SAFETY COMPLEX, SPACE NEEDS STUDY
SOUTHBOROUGH, MASSACHUSETTS**

SHARED SPACE

4.8 EMERGENCY GENERATOR TRANSFER

Adjacency Requirement	Locate next to Electrical Room
Public Access	None
Security Requirements	Moderate
Contract Millwork / Equipment	None
Floor	Concrete w/ hardener
Walls	GWB, painted
Ceiling	None
Lighting / Electrical	LED, utility
HVAC / Plumbing	None
Special Needs	Painted 3/4" plywood panels mounted to walls for mounting of electrical equipment
Owner supplied Furn. / Equip.	None

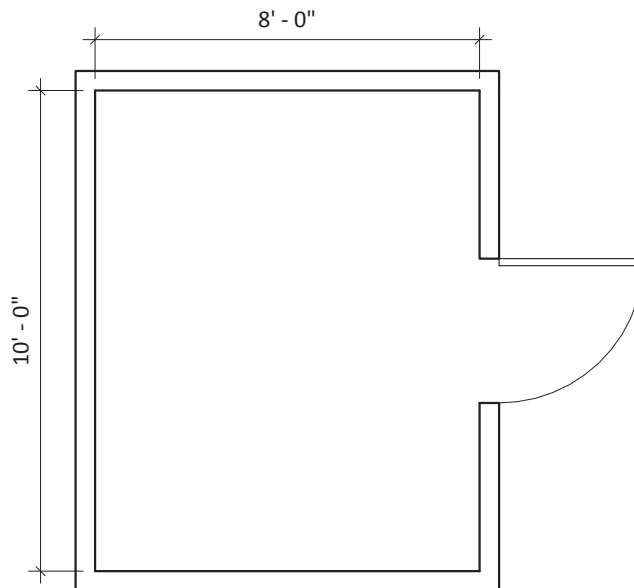

○ **EMERGENCY GENERATOR TRANSFER**
1/4" = 1'-0"

POLICE DEPARTMENT SPACE NEEDS

Police Department
Kenneth Paulus, Police Chief

**PUBLIC SAFETY COMPLEX, SPACE NEEDS STUDY
SOUTHBOROUGH, MASSACHUSETTS**

POLICE DEPARTMENT

5.1 POLICE CHIEF'S OFFICE

Adjacency Requirement	Adjacent to Administrative Assistants, Deputy Chief and Conference Room
Public Access	Moderate
Security Requirements	Moderate, controlled
Contract Millwork / Equipment	None
Floor	Carpet tile
Walls	GWB, painted w/ chair rail
Ceiling	ACT
Lighting / Electrical	Indirect LED; CATV
HVAC / Plumbing	A/C
Special Needs	None
Owner supplied Furn. / Equip.	Desk with return and credenza w/ (2) 42" 2-drawer lockable lateral files, (2) 36" 4-drawer lockable lateral files, (1) 30" coat cabinet, overhead storage bins, desk chair, (2) guest chairs, (1) 3' long, full height bookcase, 4' round conf table w/ 4 chairs, multi-function printer; TV

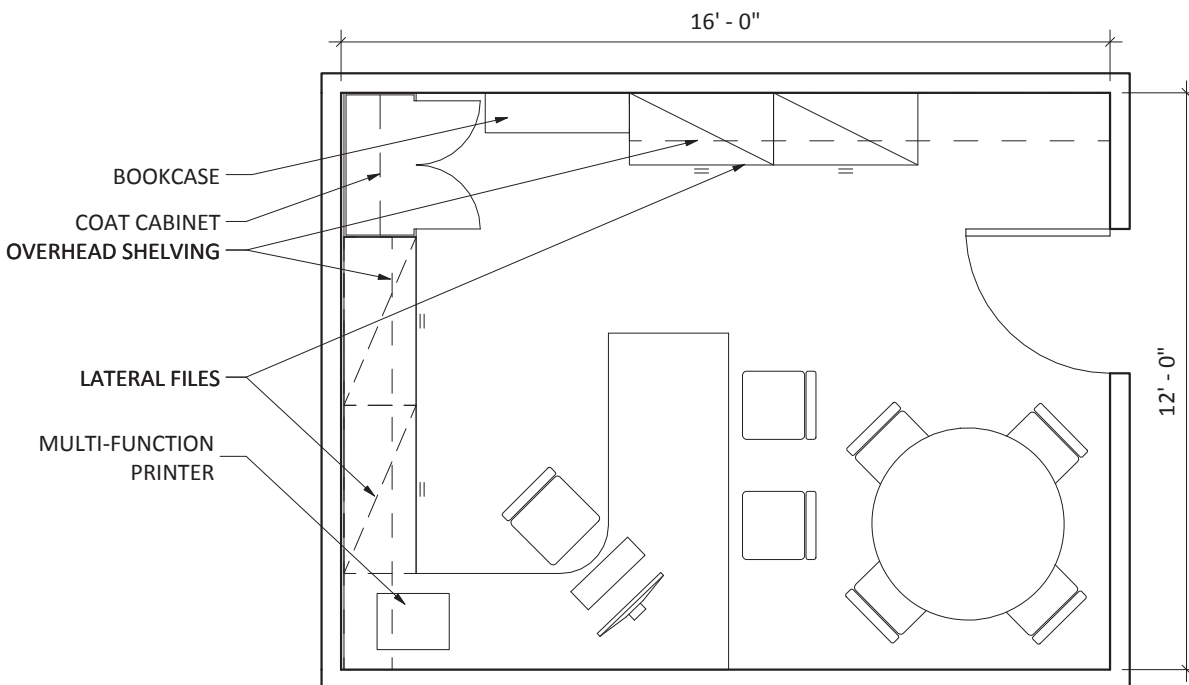

POLICE CHIEF'S OFFICE
1/4" = 1'-0"

**PUBLIC SAFETY COMPLEX, SPACE NEEDS STUDY
SOUTHBOROUGH, MASSACHUSETTS**

POLICE DEPARTMENT

5.2 LIEUTENANT'S OFFICE

Adjacency Requirement	Near Chief and Conference Room
Public Access	Minimal
Security Requirements	Moderate, controlled
Contract Millwork / Equipment	None
Floor	Carpet tile
Walls	GWB, painted
Ceiling	ACT
Lighting / Electrical	Indirect LED; CATV
HVAC / Plumbing	A/C
Special Needs	None
Owner supplied Furn. / Equip.	Desk with return, and credenza w/ 42" 2-drawer lateral file, 24" coat cabinet, overhead storage bins, desk chair, (2) guest chairs, (2) 5-drawer lateral files, bookcase

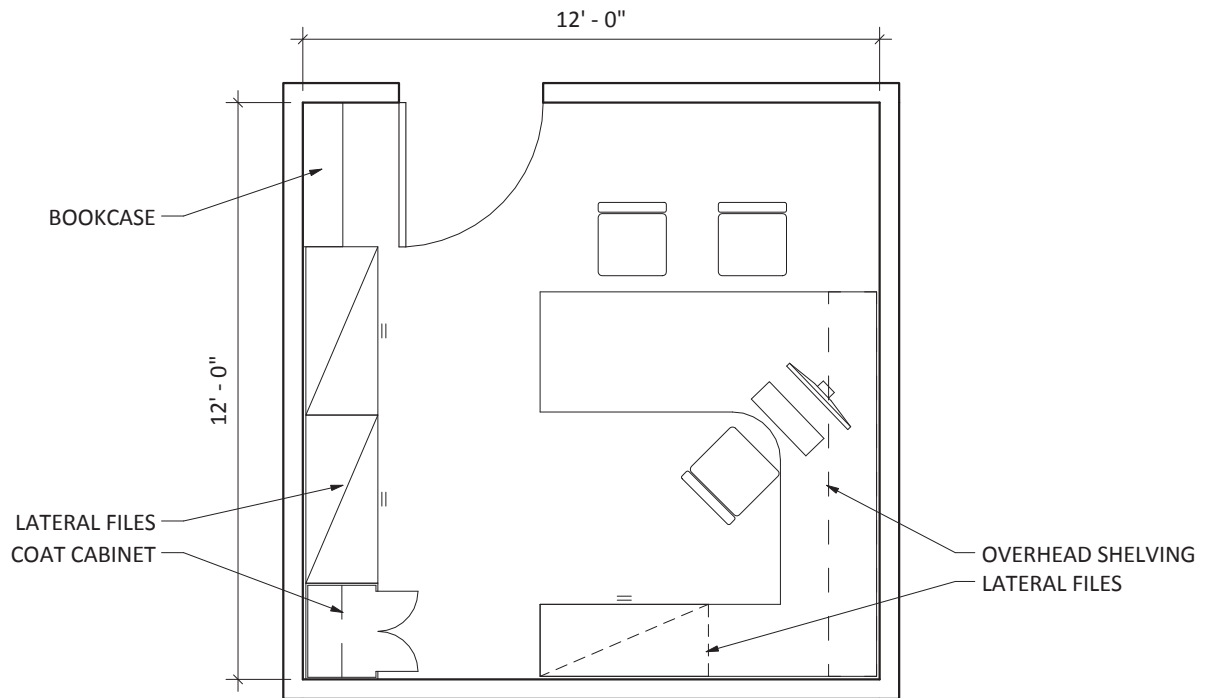

LIEUTENANT'S OFFICE
1/4" = 1'-0"

**PUBLIC SAFETY COMPLEX, SPACE NEEDS STUDY
SOUTHBOROUGH, MASSACHUSETTS**

POLICE DEPARTMENT

5.3 BUSINESS ADMINISTRATOR

Adjacency Requirement	Easy Access from Public Lobby; Near Chief's Office. Good access to records.
Public Access	Moderate
Security Requirements	Moderate
Contract Millwork / Equipment	None
Floor	Carpet tile
Walls	GWB, painted
Ceiling	ACT
Lighting / Electrical	Indirect LED; CATV
HVAC / Plumbing	A/C
Special Needs	None
Owner supplied Furn. / Equip.	Desk w/ return & credenza. (1) 42" 2-drawer lateral file, overhead storage bins, (1) desk chair, (2) 4-drawer lateral files, coat cabinet; Waiting area: (2) chairs & magazine table

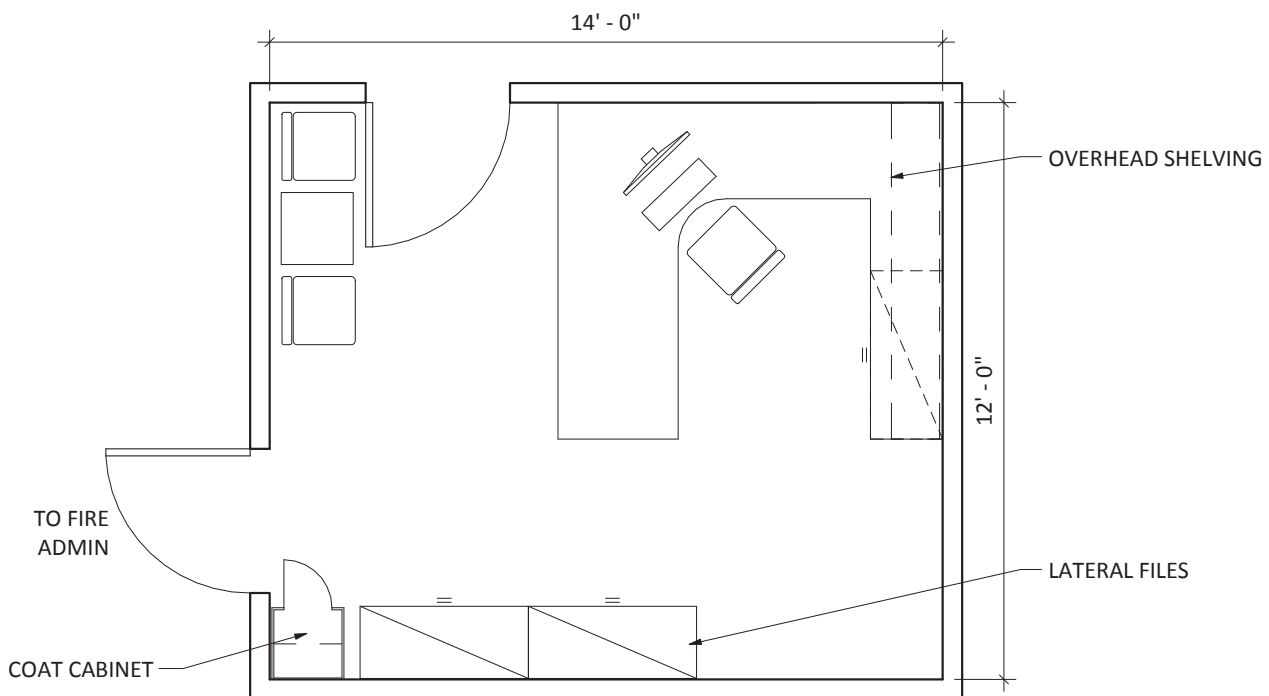

BUSINESS ADMINISTRATOR
1/4" = 1'-0"

**PUBLIC SAFETY COMPLEX, SPACE NEEDS STUDY
SOUTHBOROUGH, MASSACHUSETTS**

POLICE DEPARTMENT

5.4 WORKROOM / OFFICE SUPPLIES

Adjacency Requirement	Adjacent to Administration & good access to Records
Public Access	None
Security Requirements	Moderate
Contract Millwork / Equipment	24" base cabinets & shelving above
Floor	Rubber or Linoleum
Walls	GWB, painted
Ceiling	ACT
Lighting / Electrical	Indirect LED
HVAC / Plumbing	A/C
Special Needs	Open to Administration (no door)
Owner supplied Furn. / Equip.	Multifunction printer, shredder, postage meter

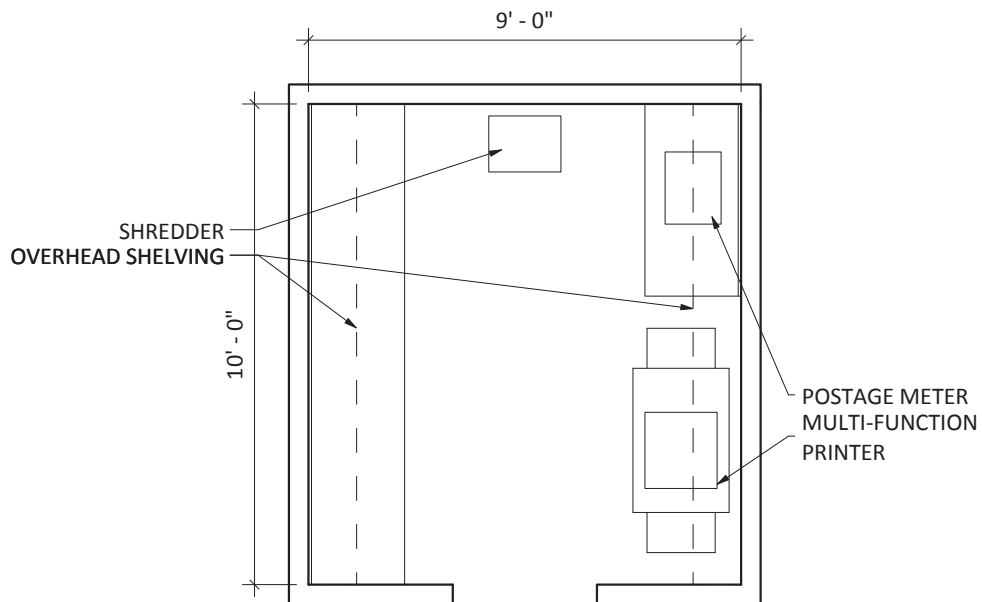

WORKROOM / OFFICE SUPPLIES
1/4" = 1'-0"

**PUBLIC SAFETY COMPLEX, SPACE NEEDS STUDY
SOUTHBOROUGH, MASSACHUSETTS**

POLICE DEPARTMENT

5.5 CONFERENCE ROOM

Adjacency Requirement	Near Chief & Lieutenants; Near Detectives
Public Access	Controlled, but easy access for visitors
Security Requirements	Low
Contract Millwork / Equipment	Fabric covered tack boards along two walls, full length marker board; chair rail. Base cabinet w/ counter
Floor	Durable carpet tile
Walls	GWB, painted
Ceiling	ACT/GWB, upgrade
Lighting / Electrical	Indirect LED, dimmers, possible pendant fixtures, data for smart board & table; CATV
HVAC / Plumbing	A/C
Special Needs	None
Owner supplied Furn. / Equip.	3 1/2' x 14' conference table w/ provision for data / power in center pedestal, (10) chairs, smart board, TV

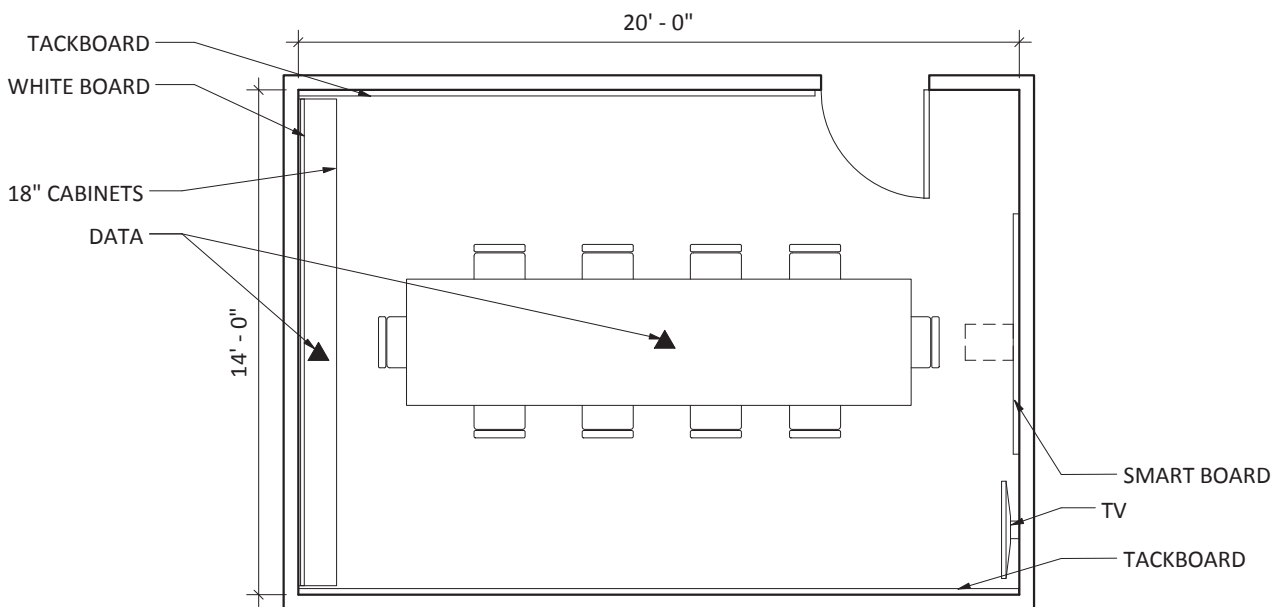

○ CONFERENCE ROOM
3/16" = 1'-0"

**PUBLIC SAFETY COMPLEX, SPACE NEEDS STUDY
SOUTHBOROUGH, MASSACHUSETTS**

POLICE DEPARTMENT

5.6 ADMINISTRATIVE TOILETS

Adjacency Requirement	Adjacent to Administration; near Administrative Waiting Area.
Public Access	Low
Security Requirements	Privacy
Contract Millwork / Equipment	Toilet accessories
Floor	Ceramic tile
Walls	GWB, painted; ceramic tile wainscot all walls
Ceiling	GWB, painted
Lighting / Electrical	LED on sensor
HVAC / Plumbing	No A/C; good exhaust; toilet, sink
Special Needs	Handicap Accessible
Owner supplied Furn. / Equip.	None

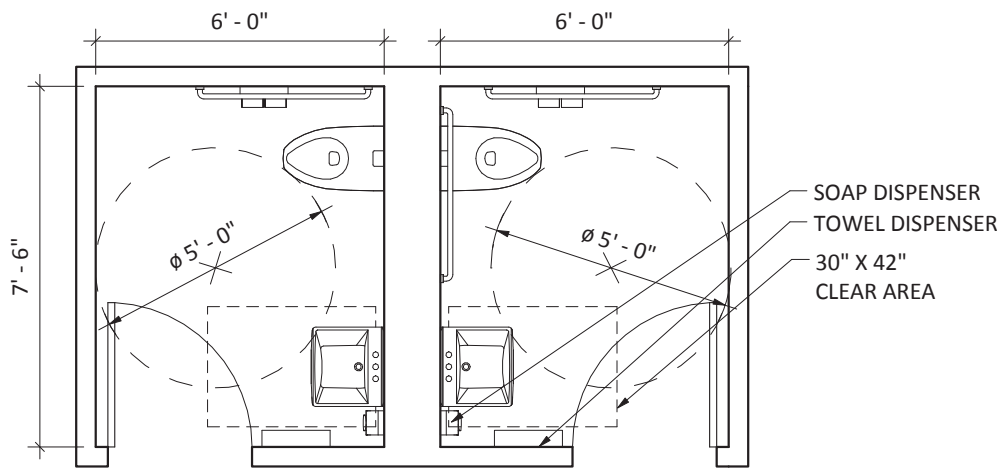

ADMINISTRATIVE TOILETS
1/4" = 1'-0"

Donham & Sweeney
ARCHITECTS
68 Harrison Ave
Boston, MA 02111
617 - 423 - 1400

**PUBLIC SAFETY COMPLEX, SPACE NEEDS STUDY
SOUTHBOROUGH, MASSACHUSETTS**

POLICE DEPARTMENT

6.1 DETECTIVE COURT OFFICER & SERGEANT DETECTIVE

Adjacency Requirement	Near Evidence. Near rear exit / entrance
Public Access	Low
Security Requirements	High
Contract Millwork / Equipment	Solid surface work counter
Floor	Carpet tile
Walls	GWB, painted
Ceiling	ACT
Lighting / Electrical	Indirect LED; CATV
HVAC / Plumbing	A/C
Special Needs	None
Owner supplied Furn. / Equip.	(4) work stations each w/ desk & return, (1) 30" 2-drawer lateral file, (1) guest chair, (1) desk chair, 10 LF overhead shelving; (2) 36" cabinets for laptops, tapes, radios, flashlights, binoculars, etc. Shredder, (4) 42" 3-drawer lateral files, TV, Multifunction printer,

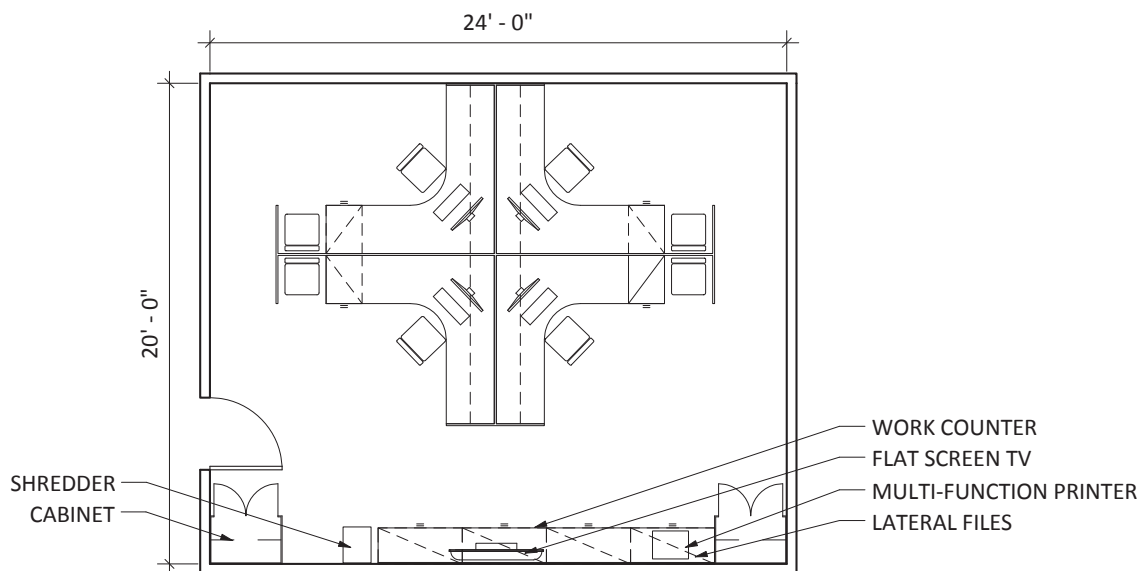

○ DETECTIVE COURT OFFICER & SERGEANT DET.
1/8" = 1'-0"

**PUBLIC SAFETY COMPLEX, SPACE NEEDS STUDY
SOUTHBOROUGH, MASSACHUSETTS**

POLICE DEPARTMENT

6.2 INTERVIEW ROOM

Adjacency Requirement	Next to Detectives
Public Access	High
Security Requirements	None
Contract Millwork / Equipment	None
Floor	Rubber or Linoleum
Walls	GWB, painted
Ceiling	ACT
Lighting / Electrical	LED; 2 position CCTV cameras; microphone w/ wall switch
HVAC / Plumbing	A/C
Special Needs	None
Owner supplied Furn. / Equip.	Table w/ (3) chairs

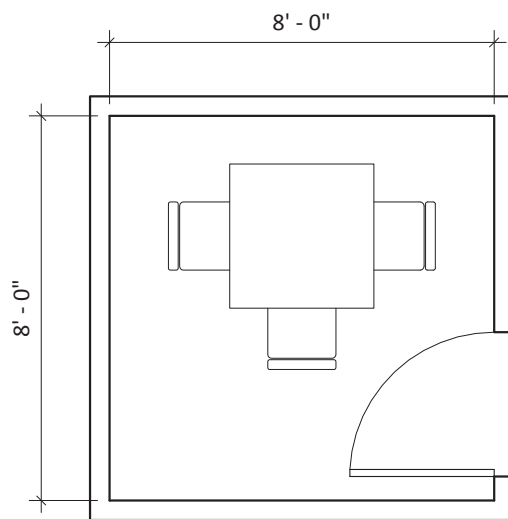

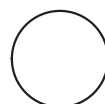
 **INTERVIEW ROOM**
1/4" = 1'-0"

**PUBLIC SAFETY COMPLEX, SPACE NEEDS STUDY
SOUTHBOROUGH, MASSACHUSETTS**

POLICE DEPARTMENT

6.3 EVIDENCE PROCESSING

Adjacency Requirement	Near Report Writing, good access to Booking. Direct access to Evidence.
Public Access	None
Security Requirements	Very high
Contract Millwork / Equipment	Base & wall cabinets; extra deep counter below fume hood, stainless steel counter w/ slots above for forms; evidence pass through (12) lockers of varying sizes, including ref.
Floor	Epoxy, Rubber or Linoleum
Walls	GWB, painted w/ plywood security liner
Ceiling	(2) Layers GWB
Lighting / Electrical	Indirect LED; CCTV cameras; data port
HVAC / Plumbing	A/C; sink, very good ventilation, exhaust for fume hood & drying chamber.
Special Needs	Handicapped accessible
Owner supplied Furn. / Equip.	Lockable refrigerator, counter mounted fuming hood (48"W, 36"D, 52"H), (1) chair, (1) Evidence Drying cabinet (36"W x 28"D x 80"H)

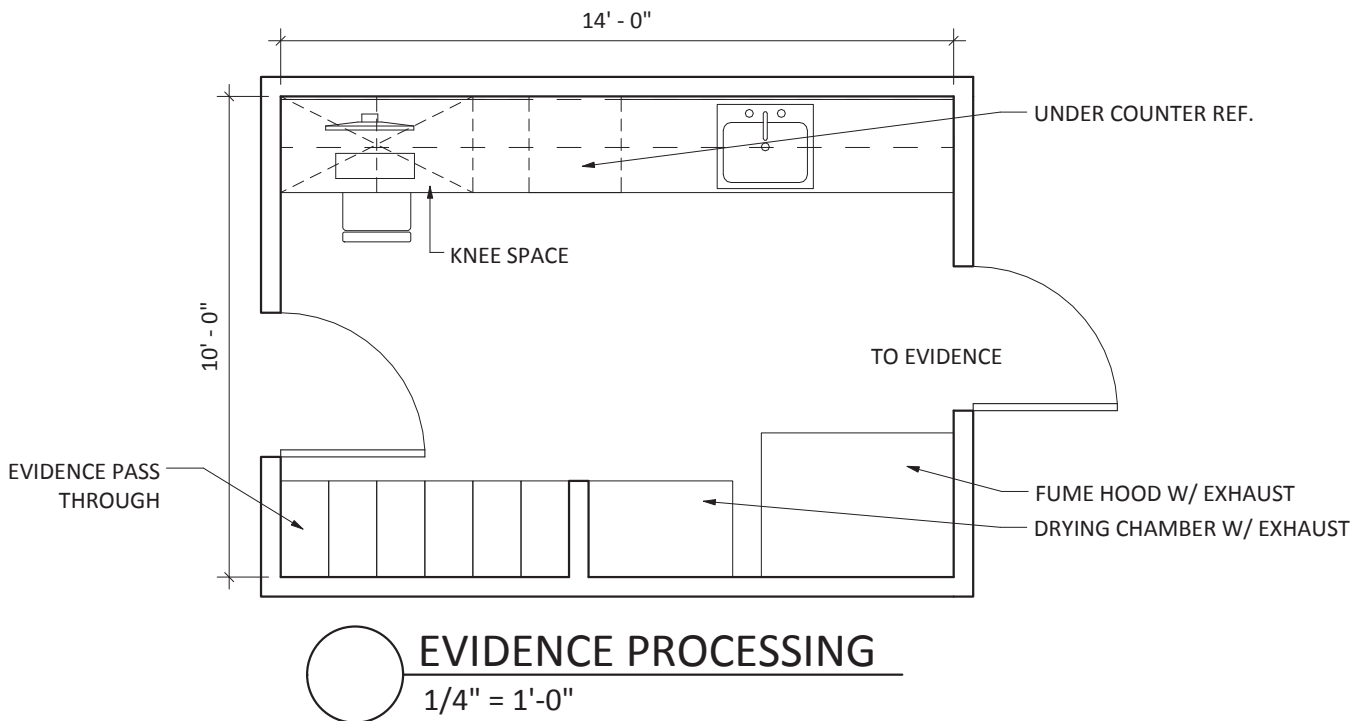

**PUBLIC SAFETY COMPLEX, SPACE NEEDS STUDY
SOUTHBOROUGH, MASSACHUSETTS**

POLICE DEPARTMENT

6.4 EVIDENCE, GENERAL

Adjacency Requirement	Direct access from Evidence Processing
Public Access	None
Security Requirements	Very High
Contract Millwork / Equipment	None
Floor	Concrete w/ hardener
Walls	GWB, painted w/ plywood security liner
Ceiling	(2) layers GWB, painted
Lighting / Electrical	LED; CCTV camera
HVAC / Plumbing	A/C, Good ventilation
Special Needs	Alarmed; Card Access; Bar code evidence scanner.
Owner supplied Furn. / Equip.	Steel shelving, refrigerator, locked gun and drug cabinets

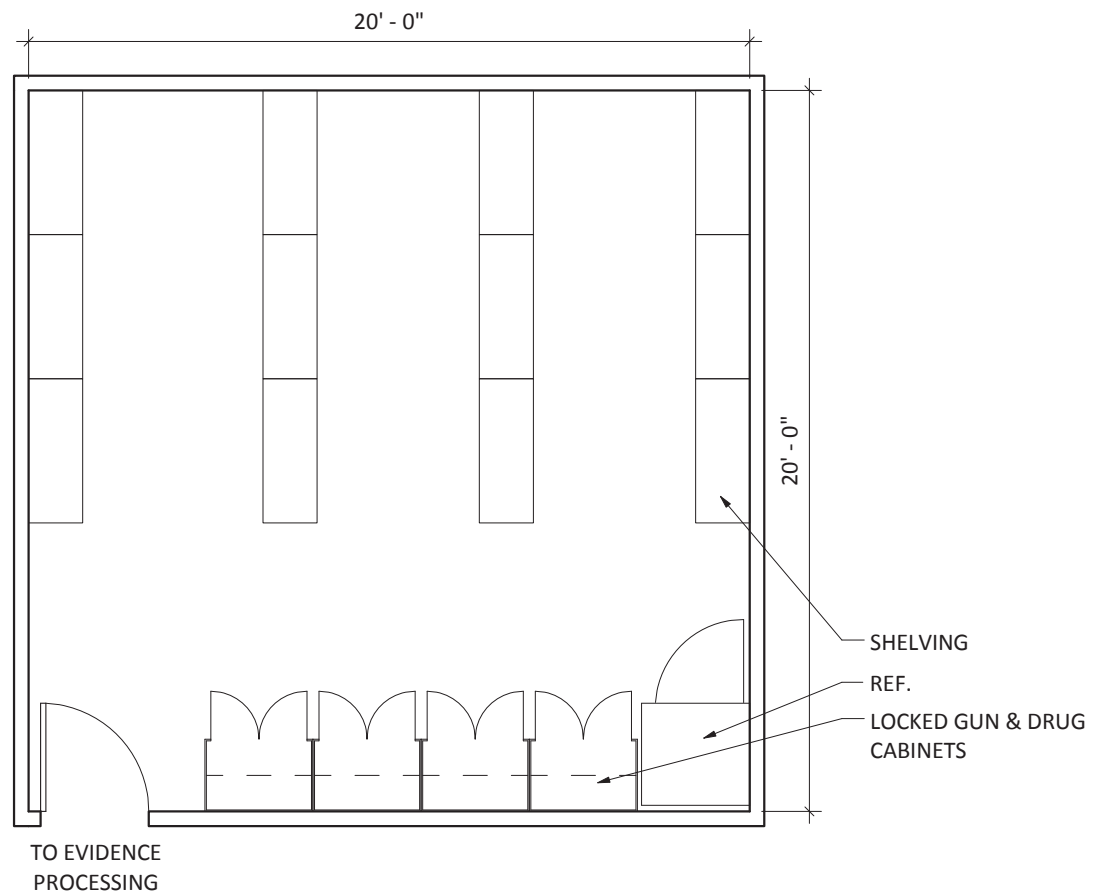

EVIDENCE, GENERAL
3/16" = 1'-0"

Donham & Sweeney
ARCHITECTS
68 Harrison Ave
Boston, MA 02111
617 - 423 - 1400

**PUBLIC SAFETY COMPLEX, SPACE NEEDS STUDY
SOUTHBOROUGH, MASSACHUSETTS**

POLICE DEPARTMENT

7.1 SUPERVISING OFFICER

Adjacency Requirement	Near Sergeants; Good access to booking
Public Access	None
Security Requirements	Moderate
Contract Millwork / Equipment	None
Floor	Carpet tile
Walls	GWB, painted
Ceiling	ACT
Lighting / Electrical	Indirect LED, CCTV, CATV
HVAC / Plumbing	A/C
Special Needs	None
Owner supplied Furn. / Equip.	Work station w/ desk & return, desk chair, guest chair, overhead storage bins, & 2-drawer file cabinet; (1) 36" 3-drawer lateral file.

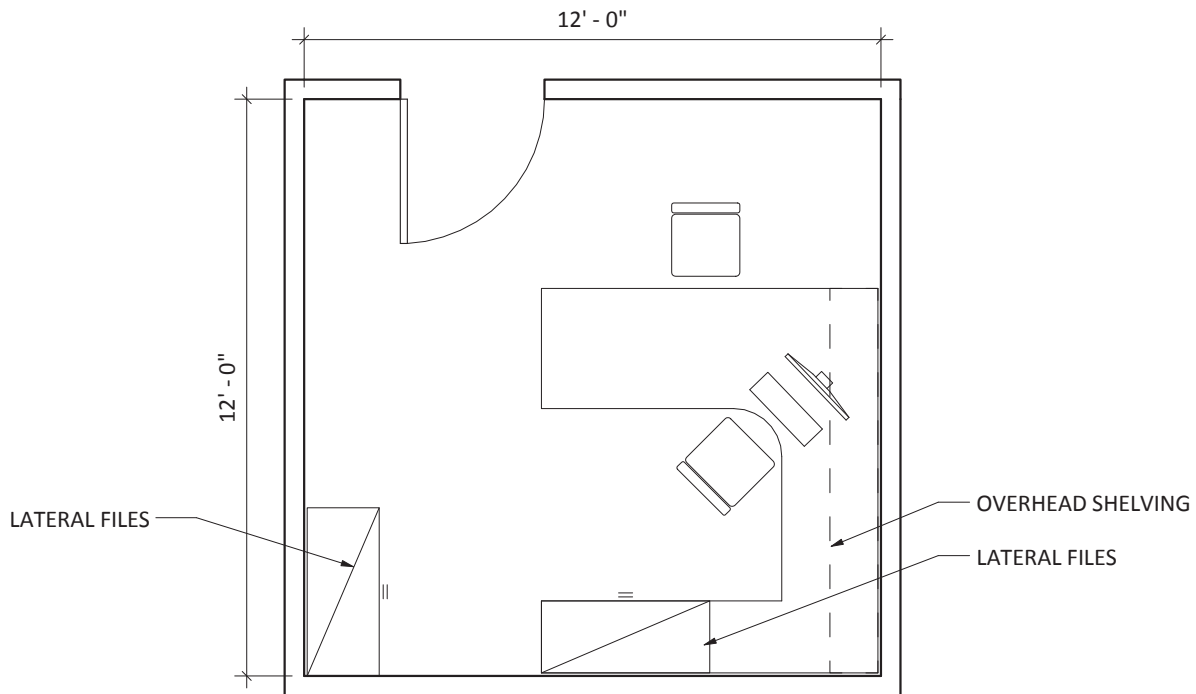

SUPERVISING OFFICER
1/4" = 1'-0"

**PUBLIC SAFETY COMPLEX, SPACE NEEDS STUDY
SOUTHBOROUGH, MASSACHUSETTS**

POLICE DEPARTMENT

7.2 ROLL CALL

Adjacency Requirement	Near Officer's entrance w/ good access to Sergeant's Office. Next to report writing and near locker room
Public Access	None
Security Requirements	High
Contract Millwork / Equipment	(44) Wall mounted mail slots, marker board, tack board
Floor	Rubber or Linoleum
Walls	GWB, painted
Ceiling	ACT
Lighting / Electrical	Indirect LED; CATV, A/V
HVAC / Plumbing	A/C
Special Needs	None
Owner supplied Furn. / Equip.	Podium, 20" x 60" training tables w/ seating for (10), smart-board, TV

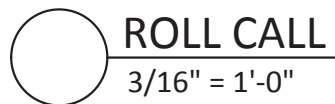
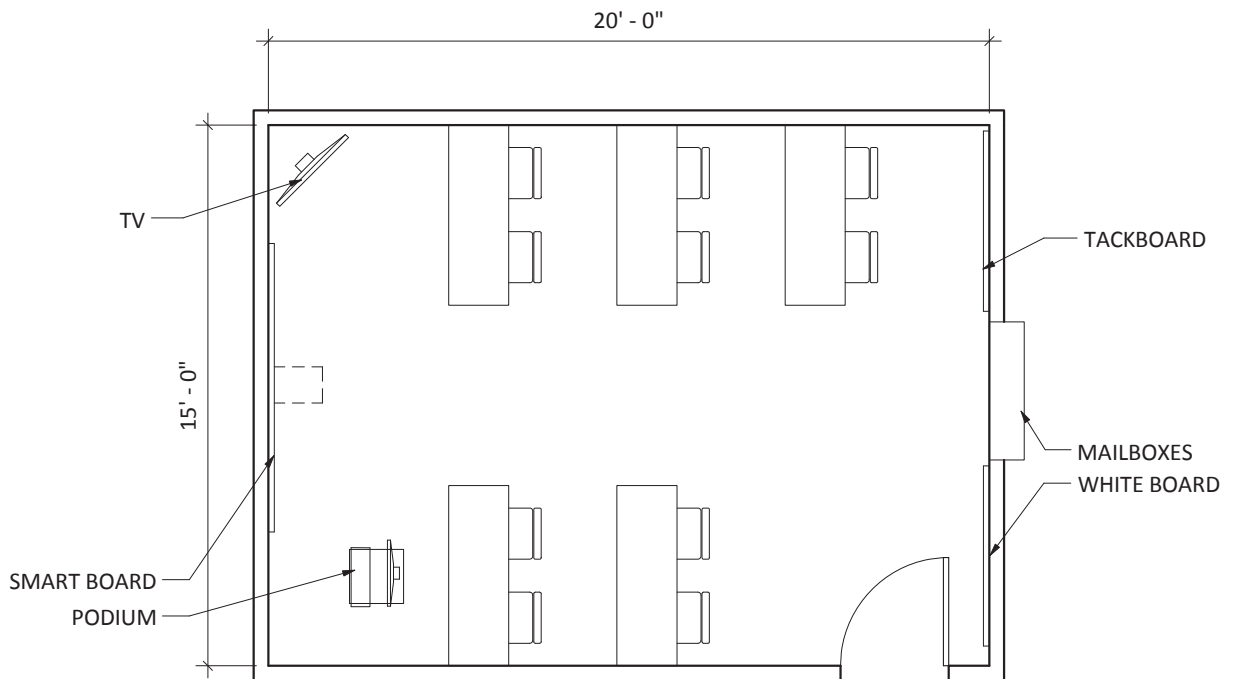

**PUBLIC SAFETY COMPLEX, SPACE NEEDS STUDY
SOUTHBOROUGH, MASSACHUSETTS**

POLICE DEPARTMENT

7.3 REPORT WRITING

Adjacency Requirement	Near Roll Call and Evidence Processing
Public Access	None
Security Requirements	High
Contract Millwork / Equipment	Solid surface work counters for computers w/ 18LF shelf above for radio chargers, binders, software, etc.
Floor	Rubber or Linoleum
Walls	GWB, painted
Ceiling	ACT
Lighting / Electrical	Indirect LED; task lighting
HVAC / Plumbing	A/C
Special Needs	None
Owner supplied Furn. / Equip.	(4) Chairs, counter space for (2) multifunction printers, (4) 2-drawer cabinets, label maker

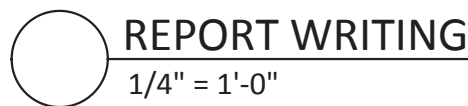
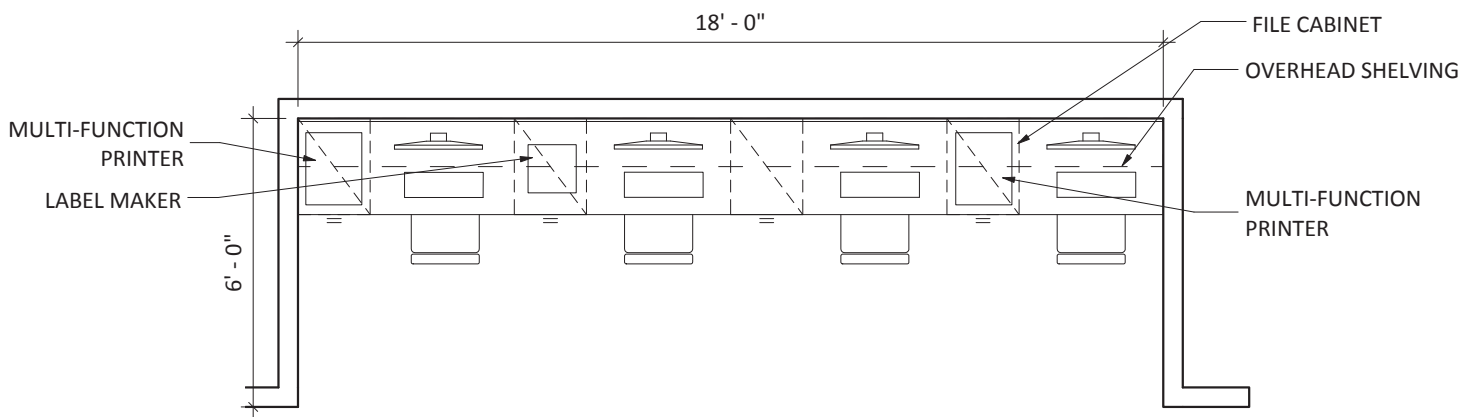

**PUBLIC SAFETY COMPLEX, SPACE NEEDS STUDY
SOUTHBOROUGH, MASSACHUSETTS**

POLICE DEPARTMENT

7.4 PATROL SERGEANTS

Adjacency Requirement	Near Roll Call. Provide easy access to Dispatch, Report Writing & Supervising Officer
Public Access	None
Security Requirements	Moderate
Contract Millwork / Equipment	6' white board
Floor	Carpet tile
Walls	GWB, painted
Ceiling	ACT
Lighting / Electrical	Indirect LED, CATV
HVAC / Plumbing	A/C
Special Needs	None
Owner supplied Furn. / Equip.	(5) Work stations each w/ desk & return, desk chair, guest chair, overhead storage bins, & 2-drawer file cabinet; (5) 36" 2-drawer lateral files.

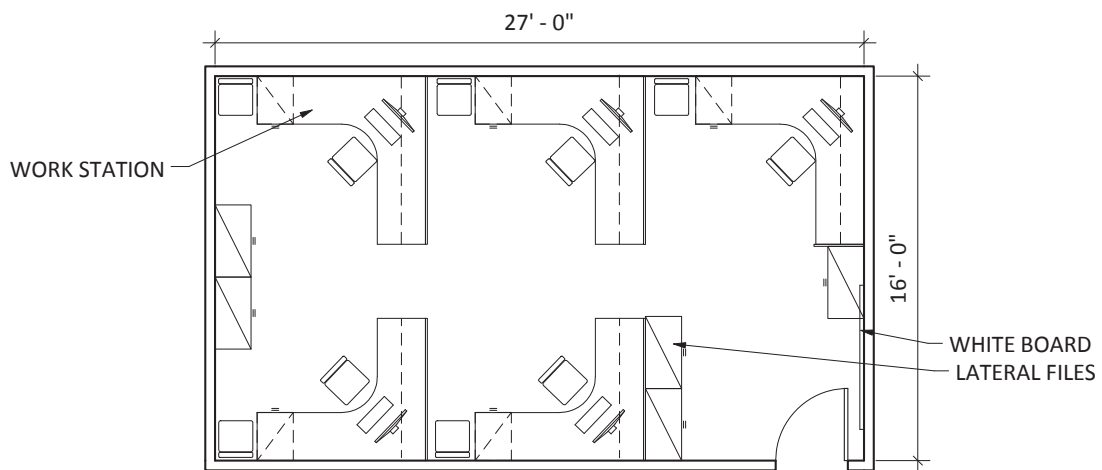

PATROL SERGEANTS
1/8" = 1'-0"

**PUBLIC SAFETY COMPLEX, SPACE NEEDS STUDY
SOUTHBOROUGH, MASSACHUSETTS**

POLICE DEPARTMENT

7.5 PATROL GEAR STORAGE

Adjacency Requirement	Near Roll Call
Public Access	None
Security Requirements	Very High
Contract Millwork / Equipment	S.S. work counter w/ shelf above
Floor	Concrete w/ hardener
Walls	CMU
Ceiling	Painted exposed structure
Lighting / Electrical	LED; power for battery charging
HVAC / Plumbing	No A/C; ventilation
Special Needs	None
Owner supplied Furn. / Equip.	(5) Metal cabinets (lockable), (2) 4'x30" deep metal storage shelving, storage for (30) flashlights, (30) radio / chargers; (8) defib. bags (18"x18"x30"), radar guns, PBT's, digital cameras

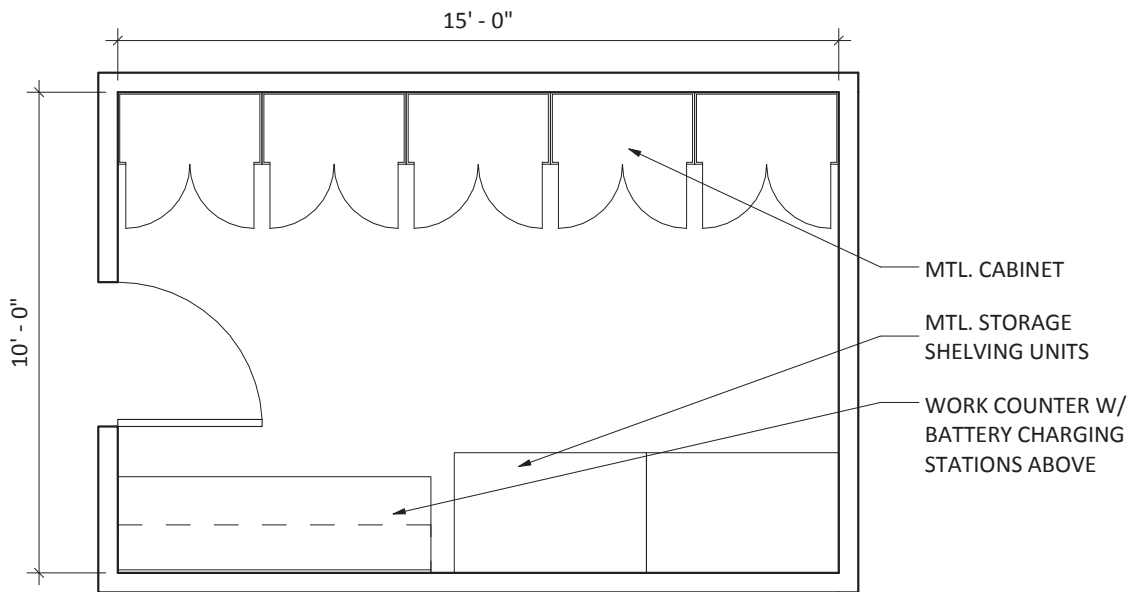

PATROL GEAR STORAGE
1/4" = 1'-0"

**PUBLIC SAFETY COMPLEX, SPACE NEEDS STUDY
SOUTHBOROUGH, MASSACHUSETTS**

POLICE DEPARTMENT

8.1 VEHICLE SALLYPORT

Adjacency Requirement	Adjacent to Booking. Good access to Detectives
Public Access	None
Security Requirements	Very high; Overhead doors controlled by Dispatch & cruiser fob
Contract Millwork / Equipment	(4) Gun lockers (for tazer & weapon)
Floor	Concrete w/ hardener or epoxy finish (non-slip)
Walls	CMU, epoxy painted
Ceiling	Exposed painted
Lighting / Electrical	LED, mounted high, CCTV
HVAC / Plumbing	Exhaust & heat only; floor drains, hose bib, drop down eye wash
Special Needs	Clearance for ambulance; 10'x10' overhead doors; tandem length. Drive-through is preferred.
Owner supplied Furn. / Equip.	None

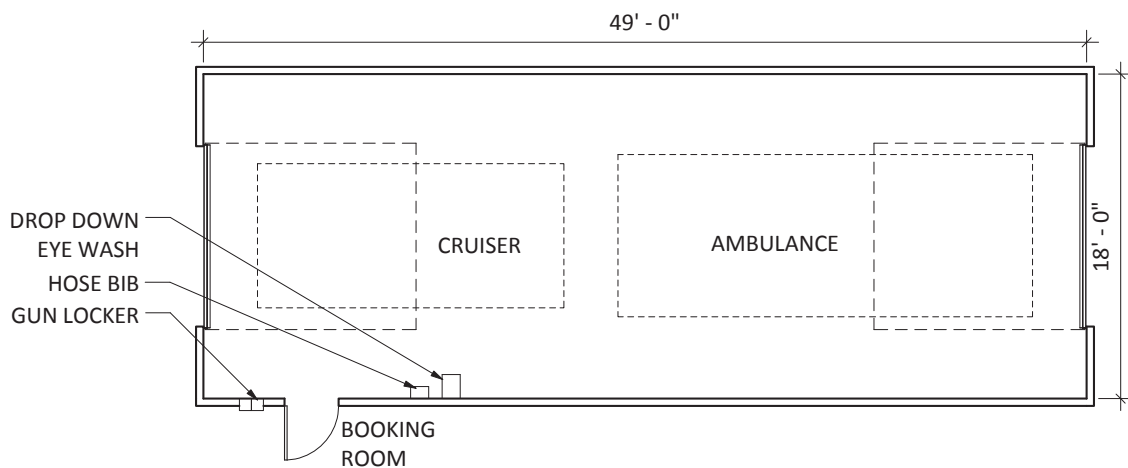

○ **VEHICLE SALLYPORT**
3/32" = 1'-0"

Donham & Sweeney
ARCHITECTS
68 Harrison Ave
Boston, MA 02111
617 - 423 - 1400

**PUBLIC SAFETY COMPLEX, SPACE NEEDS STUDY
SOUTHBOROUGH, MASSACHUSETTS**

POLICE DEPARTMENT

8.2 BOOKING

Adjacency Requirement	Next to Vehicle Sallyport & Detention Cells. Close to Supervising Officer. Shower & Holding Room located adjacent.
Public Access	None
Security Requirements	Very high
Contract Millwork / Equipment	Stainless steel counter w/ low CMU wall. Booking counter to be 6' long. Provide storage for forms. (5) 12"x 24" property lockers. (4) evidence storage lockers in various sizes. Built-in S.S. bench, stainless steel Murphy bars at bench & at booking counter. Provide S.S. counter for photo, fingerprinting, breathalyser w/ printer below
Floor	Concrete w/ epoxy finish (non-slip)
Walls	CMU w/ epoxy finish
Ceiling	(2) Layers GWB
Lighting / Electrical	All security type recessed LED, bright; CCTV; panic button; remote control for cell water & toilet flush and lighting
HVAC / Plumbing	A/C; good ventilation, separate manual exhaust for stun spray fumes
Special Needs	Supervised egress exit through Sallyport
Owner supplied Furn. / Equip.	None

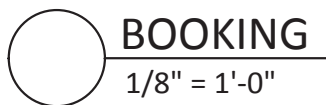
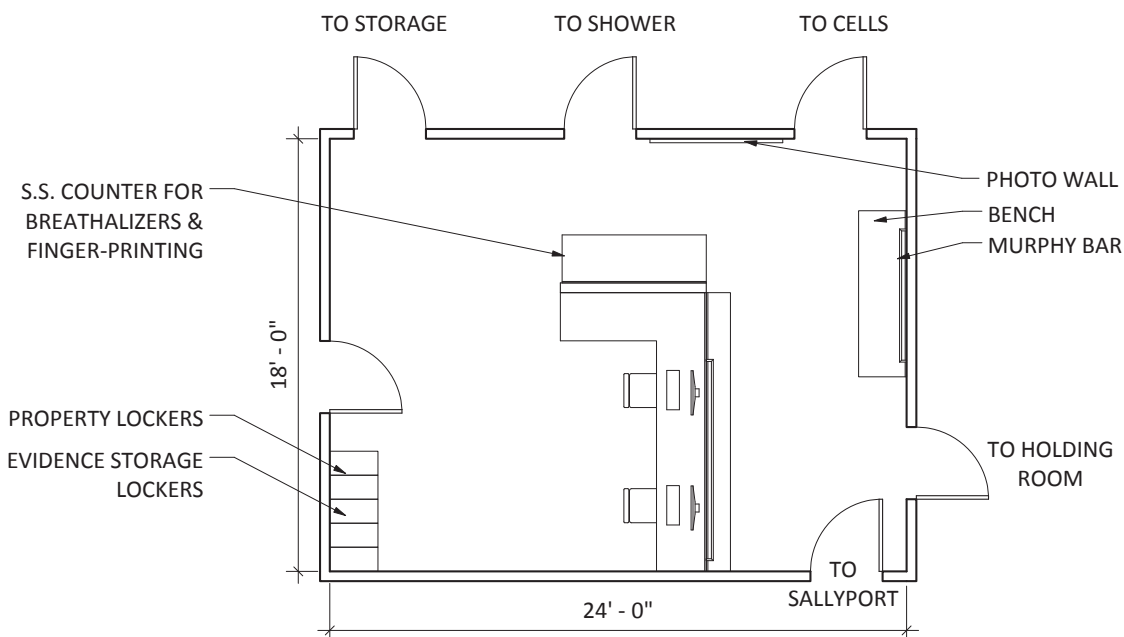

**PUBLIC SAFETY COMPLEX, SPACE NEEDS STUDY
SOUTHBOROUGH, MASSACHUSETTS**

POLICE DEPARTMENT

8.3 STORAGE CLOSET

Adjacency Requirement	Locate within Detention area
Public Access	None
Security Requirements	High - locked at all times
Contract Millwork / Equipment	Adjustable metal shelving on wall standards
Floor	Epoxy (non-slip)
Walls	CMU, painted
Ceiling	(2) Layers GWB
Lighting / Electrical	Utility
HVAC / Plumbing	None
Special Needs	None
Owner supplied Furn. / Equip.	None

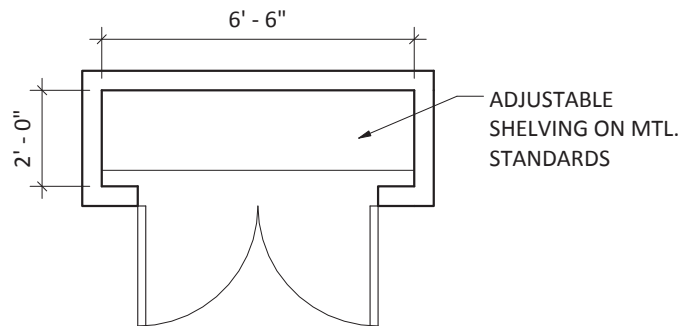

STORAGE CLOSET
1/4" = 1'-0"

**PUBLIC SAFETY COMPLEX, SPACE NEEDS STUDY
SOUTHBOROUGH, MASSACHUSETTS**

POLICE DEPARTMENT

8.4 DETENTION SHOWER

Adjacency Requirement	Access from Booking
Public Access	None
Security Requirements	Very high
Contract Millwork / Equipment	None
Floor	Epoxy (non-slip) - slope to drain
Walls	CMU w/ epoxy paint
Ceiling	(2) Layers GWB
Lighting / Electrical	Recessed, vapor & tamper proof
HVAC / Plumbing	Exhaust needed, suicide resistant fixture, drains
Special Needs	Door opens outward, handicapped accessible
Owner supplied Furn. / Equip.	None

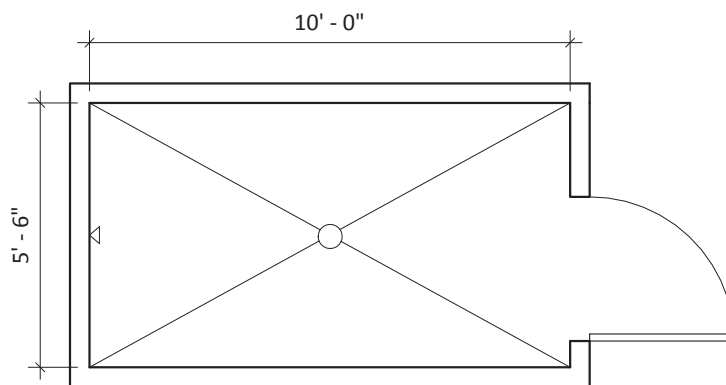

 **DETENTION SHOWER**
1/4" = 1'-0"

**PUBLIC SAFETY COMPLEX, SPACE NEEDS STUDY
SOUTHBOROUGH, MASSACHUSETTS**

POLICE DEPARTMENT

8.5 HOLDING ROOM

Adjacency Requirement	Next to Booking
Public Access	None
Security Requirements	Very high
Contract Millwork / Equipment	Stainless steel bench
Floor	Concrete w/ epoxy (non-slip), pitch to drain outside of room
Walls	CMU w/ epoxy paint
Ceiling	(2) Layers GWB
Lighting / Electrical	Recessed security fixtures; CCTV monitoring, mic & speaker
HVAC / Plumbing	A/C, good ventilation
Special Needs	Hinged detention door. Capacity for (4) persons
Owner supplied Furn. / Equip.	None

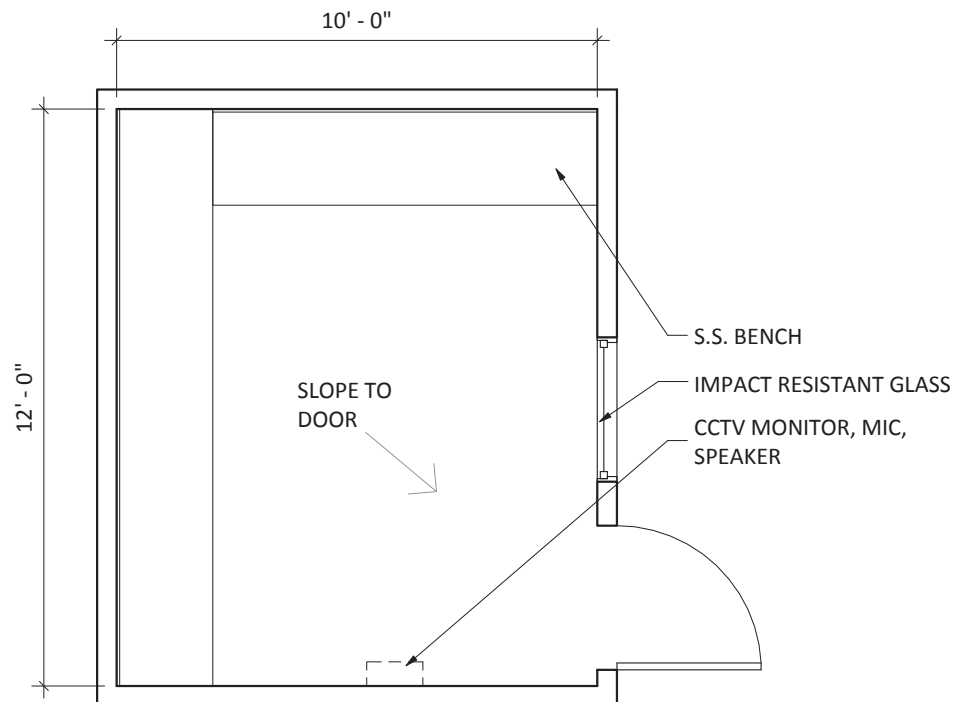

○ **HOLDING ROOM**
1/4" = 1'-0"

**PUBLIC SAFETY COMPLEX, SPACE NEEDS STUDY
SOUTHBOROUGH, MASSACHUSETTS**

POLICE DEPARTMENT

8.6 DETENTION CELLS

Adjacency Requirement	Next to Booking
Public Access	None
Security Requirements	Very high
Contract Millwork / Equipment	Stainless steel bunk
Floor	Concrete w/ epoxy topping, pitch to corridor drain
Walls	CMU w/ epoxy paint
Ceiling	Welded steel plate
Lighting / Electrical	Recessed security fixtures; CCTV monitoring; wall-mounted phone, mic & speaker
HVAC / Plumbing	A/C, good ventilation, combination toilet/sink detention fixture, security grilles
Special Needs	Sight & sound separate cells provide flexibility in use of detention rooms. Meet Mass Police Accrediting Standards, Mass Department of Public Health Regulations & Mass Access Code. All to be HC accessible.
Owner supplied Furn. / Equip.	None

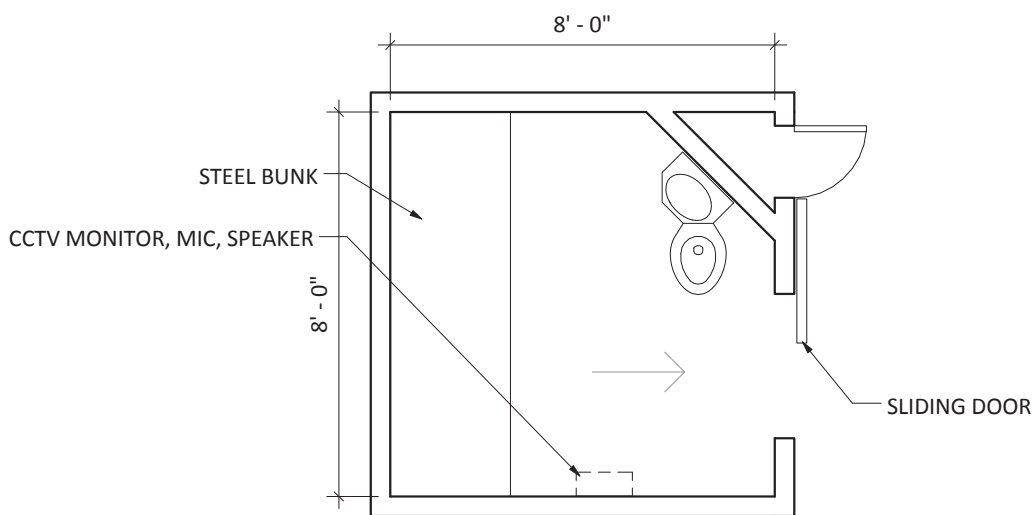

DETENTION CELLS
1/4" = 1'-0"

**PUBLIC SAFETY COMPLEX, SPACE NEEDS STUDY
SOUTHBOROUGH, MASSACHUSETTS**

POLICE DEPARTMENT

8.7 INTERVIEW / STATUS OFFENDER ROOM

Adjacency Requirement	Adjacent to Supervising Officer
Public Access	Limited
Security Requirements	Moderate
Contract Millwork / Equipment	None
Floor	Rubber or Linoleum
Walls	GWB, painted
Ceiling	ACT
Lighting / Electrical	LED 2-level direct/indirect; A/V capacity, mic & speaker, panic button just outside room
HVAC / Plumbing	A/C
Special Needs	One-way glass, no exterior windows, plain room
Owner supplied Furn. / Equip.	3'x 3' table w/ (3) chairs

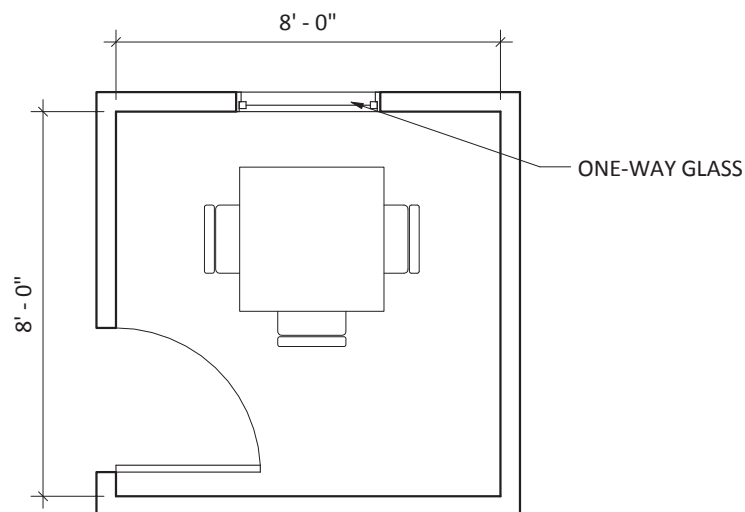

 **INTERVIEW / STATUS OFFENDER ROOM**
1/4" = 1'-0"

**PUBLIC SAFETY COMPLEX, SPACE NEEDS STUDY
SOUTHBOROUGH, MASSACHUSETTS**

POLICE DEPARTMENT

9.1 BREAK ROOM

Adjacency Requirement	Near roll call
Public Access	None
Security Requirements	Moderate
Contract Millwork / Equipment	24" base & wall cabinets above
Floor	Rubber or Linoleum
Walls	GWB, painted
Ceiling	ACT
Lighting / Electrical	Indirect LED on sensor: CATV
HVAC / Plumbing	A/C; sink
Special Needs	Handicapped accessible; exterior windows
Owner supplied Furn. / Equip.	Refrigerator, microwave, coffee maker, large bowl sink, 4-burner range & oven, vent hood, recycling bins, 3 1/2' x 10' table w/ (6) chairs, TV

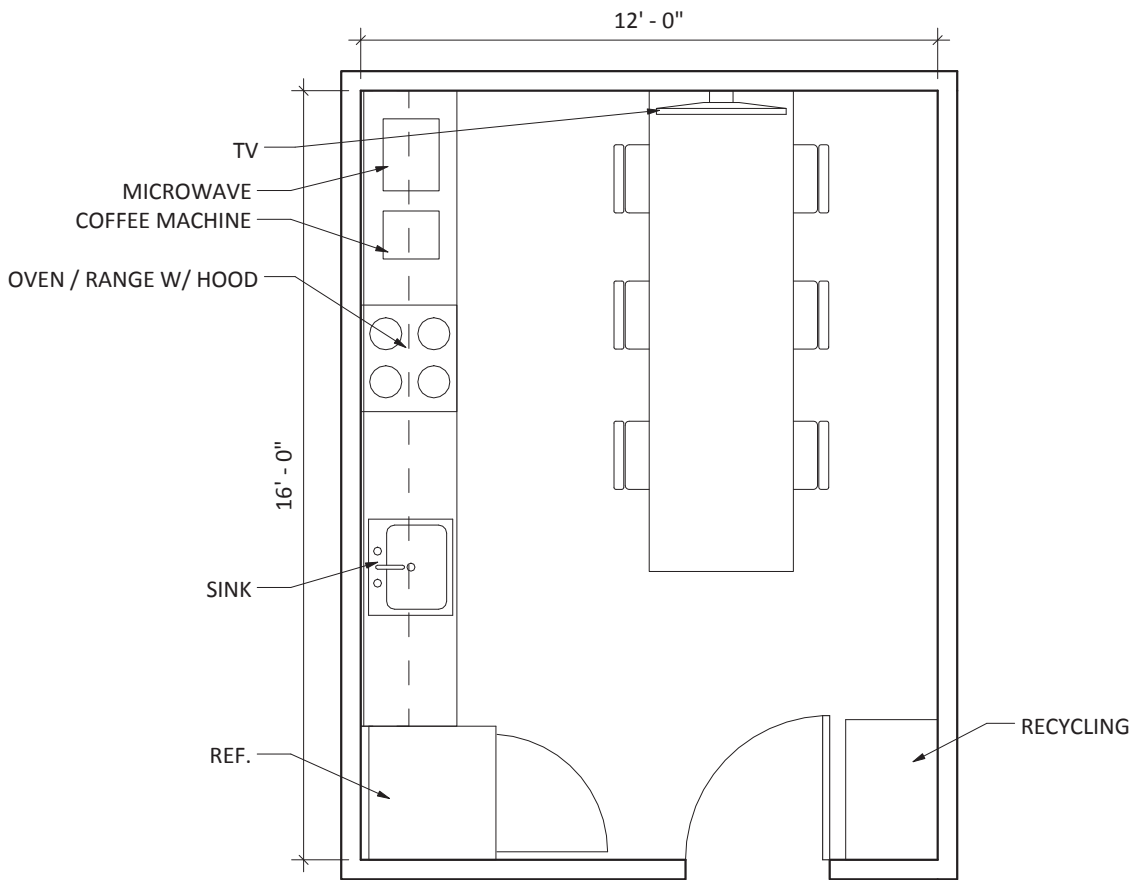

BREAK ROOM
1/4" = 1'-0"

**PUBLIC SAFETY COMPLEX, SPACE NEEDS STUDY
SOUTHBOROUGH, MASSACHUSETTS**

POLICE DEPARTMENT

9.2 STAFF TOILET ROOMS

Adjacency Requirement	Near Patrol and/or Detectives depending on Administration Toilets
Public Access	None
Security Requirements	Privacy
Contract Millwork / Equipment	Toilet accessories
Floor	Ceramic tile
Walls	GWB, painted, ceramic tile wainscot all walls
Ceiling	GWB, painted
Lighting / Electrical	LED on sensor
HVAC / Plumbing	No A/C; good exhaust; toilet & sink
Special Needs	Handicap Accessible
Owner supplied Furn. / Equip.	None

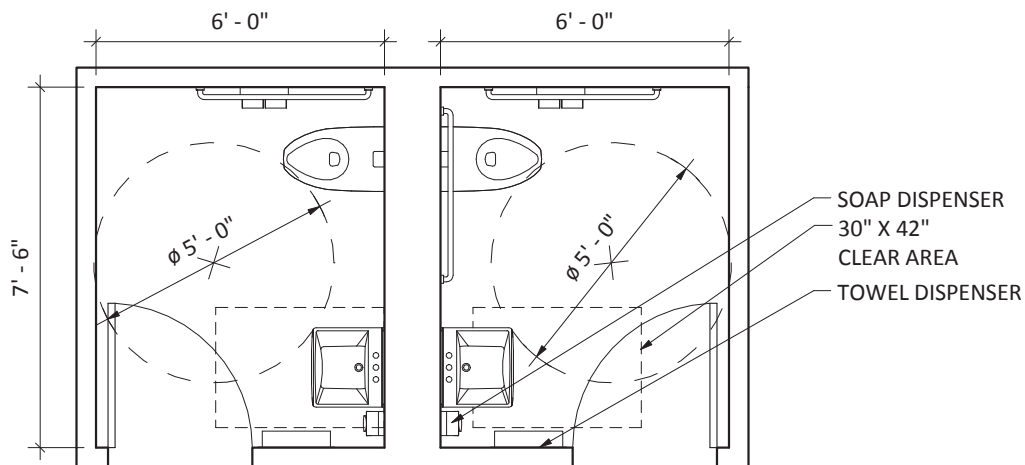

○ **STAFF TOILET ROOMS**
1/4" = 1'-0"

**PUBLIC SAFETY COMPLEX, SPACE NEEDS STUDY
SOUTHBOROUGH, MASSACHUSETTS**

POLICE DEPARTMENT

9.3 MEN'S LOCKERS & SHOWERS

Adjacency Requirement	Easy access from Officer's entrance & Patrol. Near Fitness.
Public Access	None
Security Requirements	High
Contract Millwork / Equipment	Lockers w/ pull out drawers under. Provide power outlet in each locker that can accommodate (3) plugs. Mirrors on end walls in locker room. (28) lockers @ 2'D x 3'W, w/ 12" attached bench/storage for Patrol Officers, mirror, toilet accessories
Floor	Ceramic tile in toilet rooms, rubber flooring in locker area
Walls	Ceramic wall tile in wet areas
Ceiling	ACT, M.R. GWB, painted
Lighting / Electrical	LED; power for locker plugs
HVAC / Plumbing	Good ventilation; floor drain; (2) sinks, (2) toilets, (2) urinals, (3) showers
Special Needs	None
Owner supplied Furn. / Equip.	Of the 28 lockers (22) lockers provided by owner (same type as above)

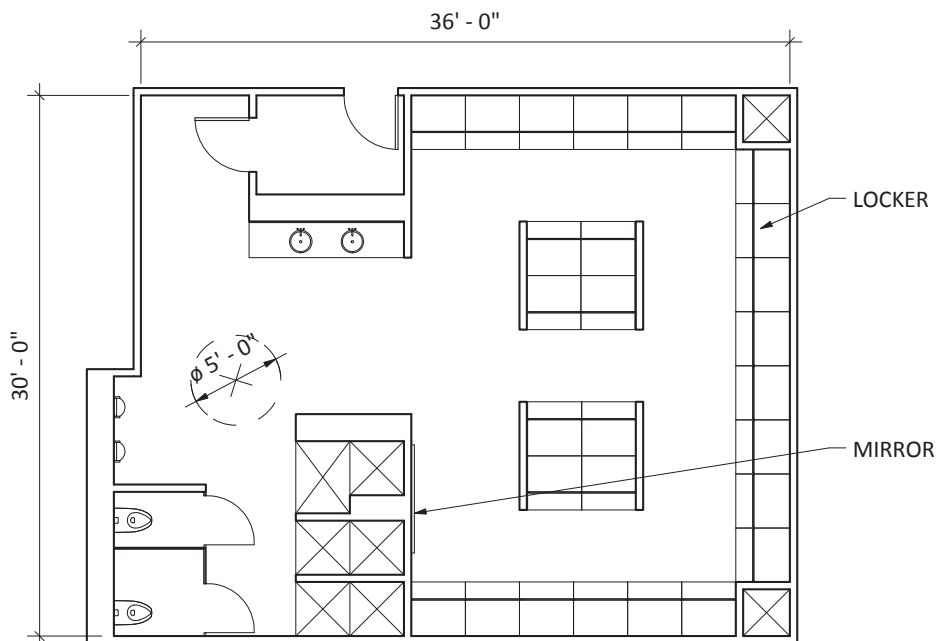

MEN'S LOCKERS & SHOWERS
3/32" = 1'-0"

**PUBLIC SAFETY COMPLEX, SPACE NEEDS STUDY
SOUTHBOROUGH, MASSACHUSETTS**

POLICE DEPARTMENT

9.4 WOMEN'S LOCKERS & SHOWER

Adjacency Requirement	Easy access from Officer's entrance & Patrol Room. Adjacent to Fitness.
Public Access	None
Security Requirements	High
Contract Millwork / Equipment	Lockers w/ pull out drawers under. Provide power outlet in each locker that can accommodate (3) plugs. Mirrors on end walls in locker room. (6) lockers @ 2'D x 3'W, w/ 12" attached benches for Patrol Officers, mirror, toilet accessories
Floor	Ceramic tile in toilet rooms, rubber flooring in locker area
Walls	Ceramic wall tile in wet areas
Ceiling	ACT, M.R. GWB, painted
Lighting / Electrical	LED; power for locker plugs
HVAC / Plumbing	Good ventilation; floor drain; (2) sinks, (1) toilet, (1) shower
Special Needs	None
Owner supplied Furn. / Equip.	None

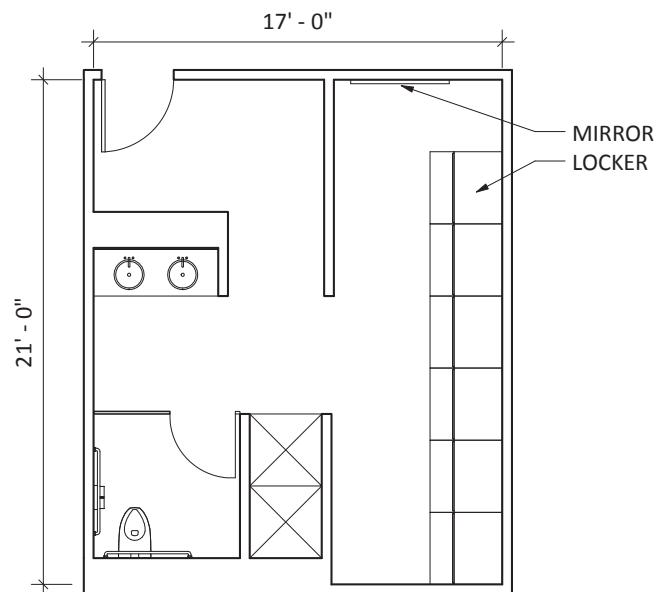

WOMEN'S LOCKERS & SHOWERS
1/8" = 1'-0"

**PUBLIC SAFETY COMPLEX, SPACE NEEDS STUDY
SOUTHBOROUGH, MASSACHUSETTS**

POLICE DEPARTMENT

9.5 ARMORY

Adjacency Requirement	Near Patrol Sergeants.
Public Access	None
Security Requirements	High
Contract Millwork / Equipment	S.S. counter / work bench, 12" metal shelving in secure closet
Floor	Concrete w/ hardener
Walls	GWB, painted
Ceiling	Exposed structure, painted
Lighting / Electrical	LED & task lighting
HVAC / Plumbing	Good ventilation. Exhaust hood at work bench. Compressed air.
Special Needs	Secure closet for armorer
Owner supplied Furn. / Equip.	Lockable: (3) gun racks, (2) steel cabinets, (2) 15" deep metal shelving cabinets for ammo & gear

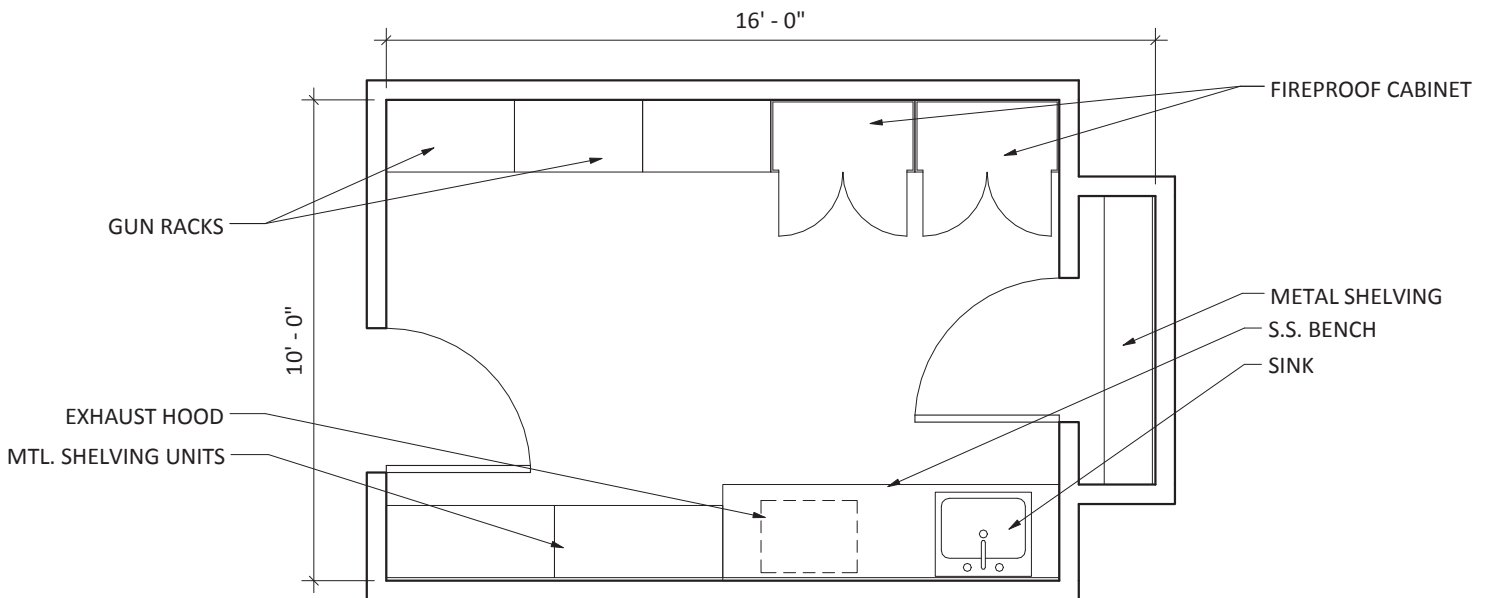

○ **ARMORY**
1/4" = 1'-0"

**PUBLIC SAFETY COMPLEX, SPACE NEEDS STUDY
SOUTHBOROUGH, MASSACHUSETTS**

POLICE DEPARTMENT

9.6 GARAGE

Adjacency Requirement	Near other garages. Near Patrol areas.
Public Access	None
Security Requirements	High
Contract Millwork / Equipment	None
Floor	Concrete w/ hardener
Walls	CMU w/ epoxy paint
Ceiling	Exposed, painted
Lighting / Electrical	LED; power for charging
HVAC / Plumbing	Good exhaust. Floordrain & hose bib.
Special Needs	Storage of (1) motorcycle & (4) patrol bicycles
Owner supplied Furn. / Equip.	None

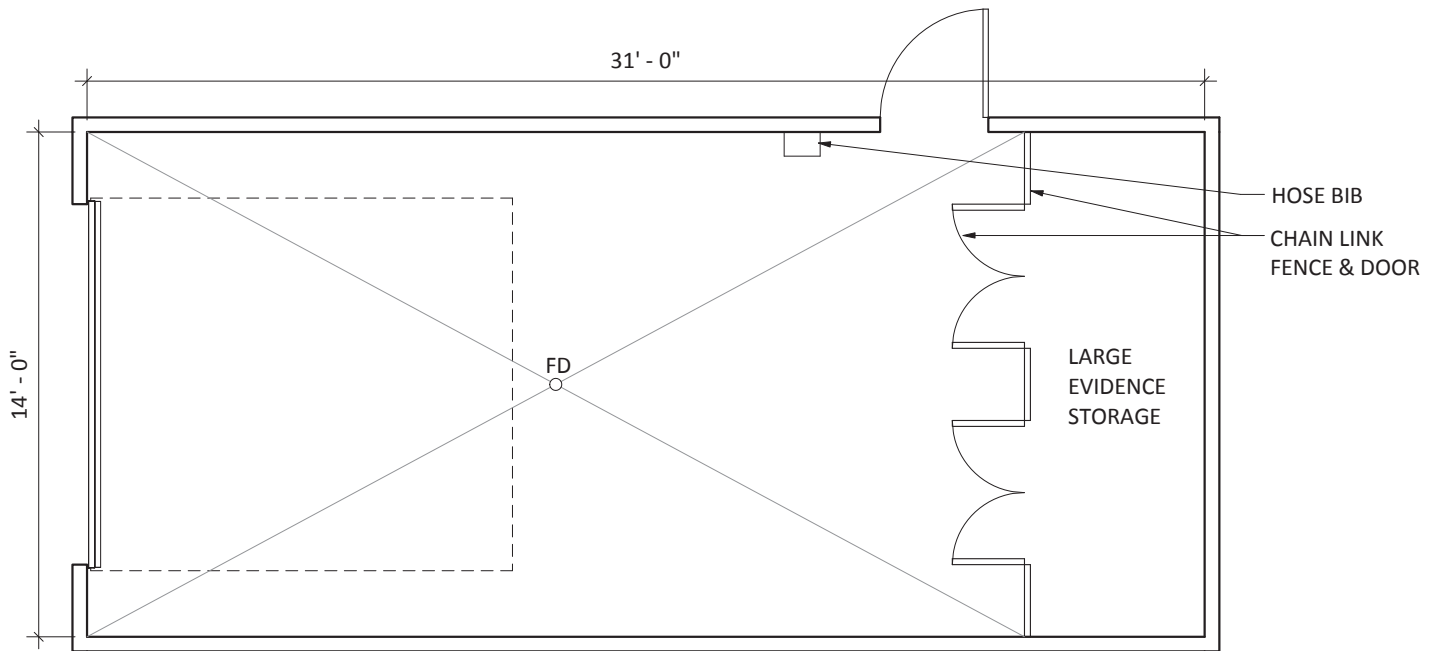

 **GARAGE**
3/16" = 1'-0"

FIRE DEPARTMENT SPACE NEEDS

Fire Department
Joseph Mauro, Fire Chief

**PUBLIC SAFETY COMPLEX, SPACE NEEDS STUDY
SOUTHBOROUGH, MASSACHUSETTS**

FIRE DEPARTMENT

10.1 FIRE CHIEF'S OFFICE

Adjacency Requirement	Adjacent to Administrative Assistant, Deputy Chief; and Conference Room
Public Access	Moderate
Security Requirements	Moderate, controlled
Contract Millwork / Equipment	White board
Floor	Carpet tile
Walls	GWB, painted
Ceiling	ACT
Lighting / Electrical	Indirect LED; CATV
HVAC / Plumbing	A/C
Special Needs	None
Owner supplied Furn. / Equip.	Desk w/ return, & credenza w/ (2) 42" 2-drawer lateral files, 36" coat cabinet, overhead storage bins, desk chair, (2) guest chairs, (2) 42" 4-drawer lateral files, bookcase, countertop printer / copier

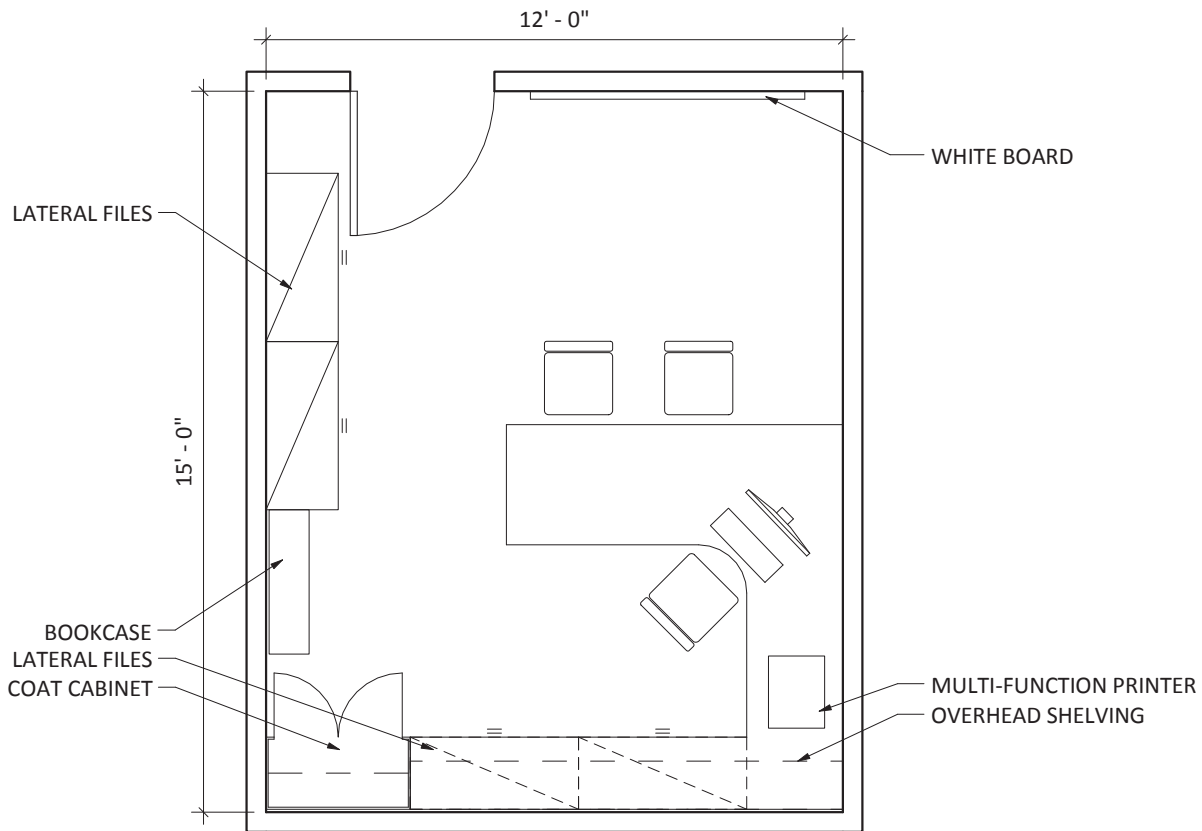

**PUBLIC SAFETY COMPLEX, SPACE NEEDS STUDY
SOUTHBOROUGH, MASSACHUSETTS**

FIRE DEPARTMENT

10.2 DEPUTY FIRE CHIEF'S OFFICE

Adjacency Requirement	Adjacent to Administrative Assistant; Chief and Conference Room
Public Access	Low
Security Requirements	Moderate, controlled
Contract Millwork / Equipment	None
Floor	Carpet tile
Walls	GWB, painted
Ceiling	ACT
Lighting / Electrical	Indirect LED; CATV
HVAC / Plumbing	A/C
Special Needs	None
Owner supplied Furn. / Equip.	Desk w/ return, & credenza w/ 42" 2-drawer lateral file, 18" coat cabinet, overhead storage bins, desk chair, (2) guest chairs, (2) 4-drawer lateral files, bookcase, printer / copier

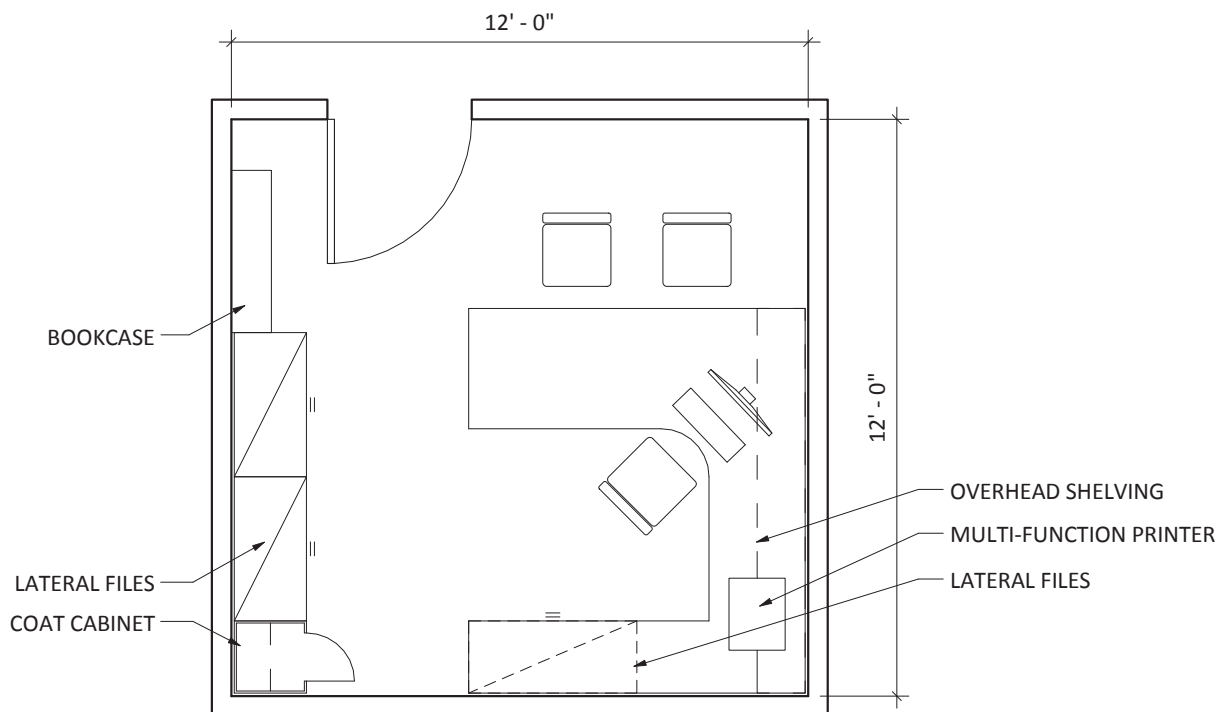

DEPUTY FIRE CHIEF'S OFFICE
1/4" = 1'-0"

Donham & Sweeney
ARCHITECTS
68 Harrison Ave
Boston, MA 02111
617 - 423 - 1400

**PUBLIC SAFETY COMPLEX, SPACE NEEDS STUDY
SOUTHBOROUGH, MASSACHUSETTS**

FIRE DEPARTMENT

10.3 CONFERENCE ROOM

Adjacency Requirement	Adjacent to Administrative Assistant; near Chief & Deputy Chief
Public Access	Moderate
Security Requirements	Moderate, controlled
Contract Millwork / Equipment	(2) White boards
Floor	Carpet tile
Walls	GWB, painted
Ceiling	ACT
Lighting / Electrical	Indirect LED; CATV
HVAC / Plumbing	A/C
Special Needs	None
Owner supplied Furn. / Equip.	3'6" x 10' table w/ (12) chairs, smart board

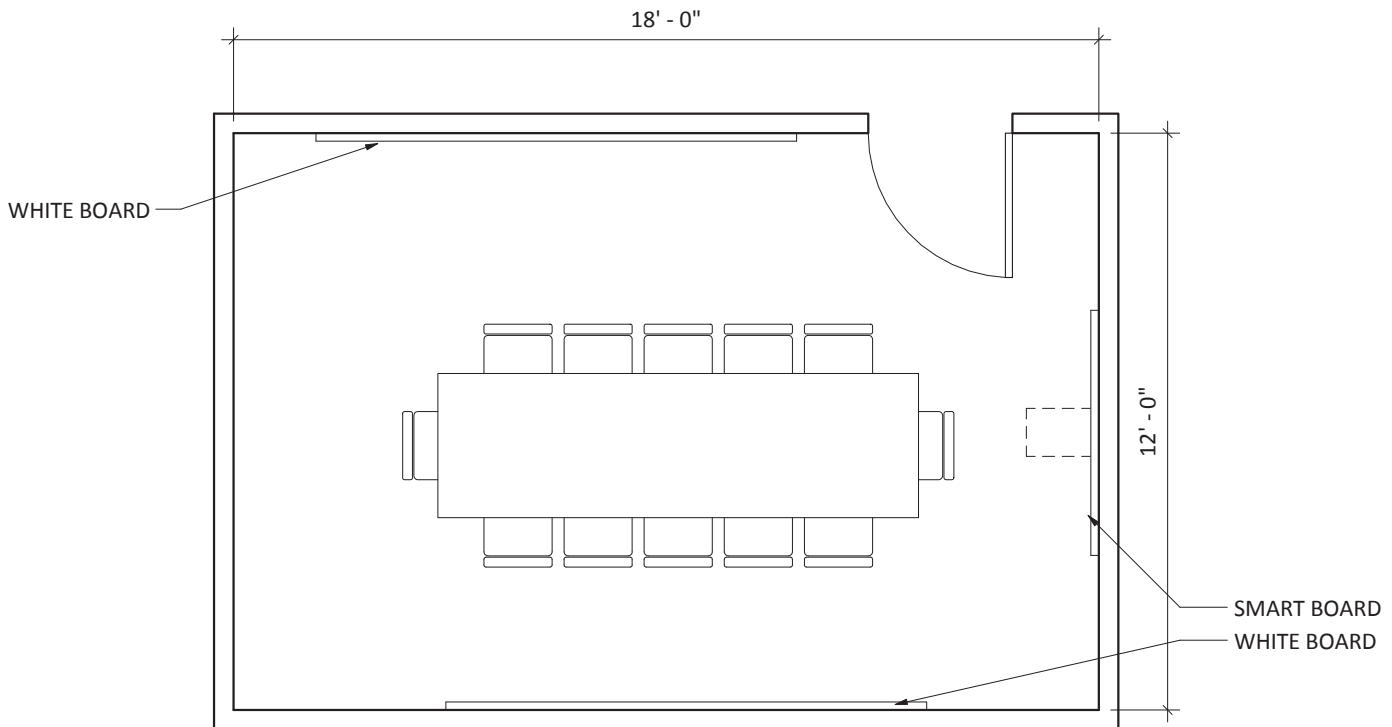

 **CONFERENCE ROOM**
1/4" = 1'-0"

**PUBLIC SAFETY COMPLEX, SPACE NEEDS STUDY
SOUTHBOROUGH, MASSACHUSETTS**

FIRE DEPARTMENT

10.4 FIRE PROTECTION & TRAINING OFFICE

Adjacency Requirement	Located near Administration, near Conference Room
Public Access	Moderate
Security Requirements	Moderate
Contract Millwork / Equipment	(2) White boards, 30" solid surface counter
Floor	Carpet tile
Walls	GWB, painted
Ceiling	ACT
Lighting / Electrical	Indirect LED
HVAC / Plumbing	A/C
Special Needs	None
Owner supplied Furn. / Equip.	2 workstations each w/ desk & return, desk chair, guest chair and overhead storage bins; 30" storage cabinet; (6) 36" 4-drawer legal size lateral files, printer / copier on counter, coat cabinet; 3' bookcase for code books; 3' x 5' plan review table w/ (4) chairs, (2) 48" flat file storage cabinets (30) drawers total

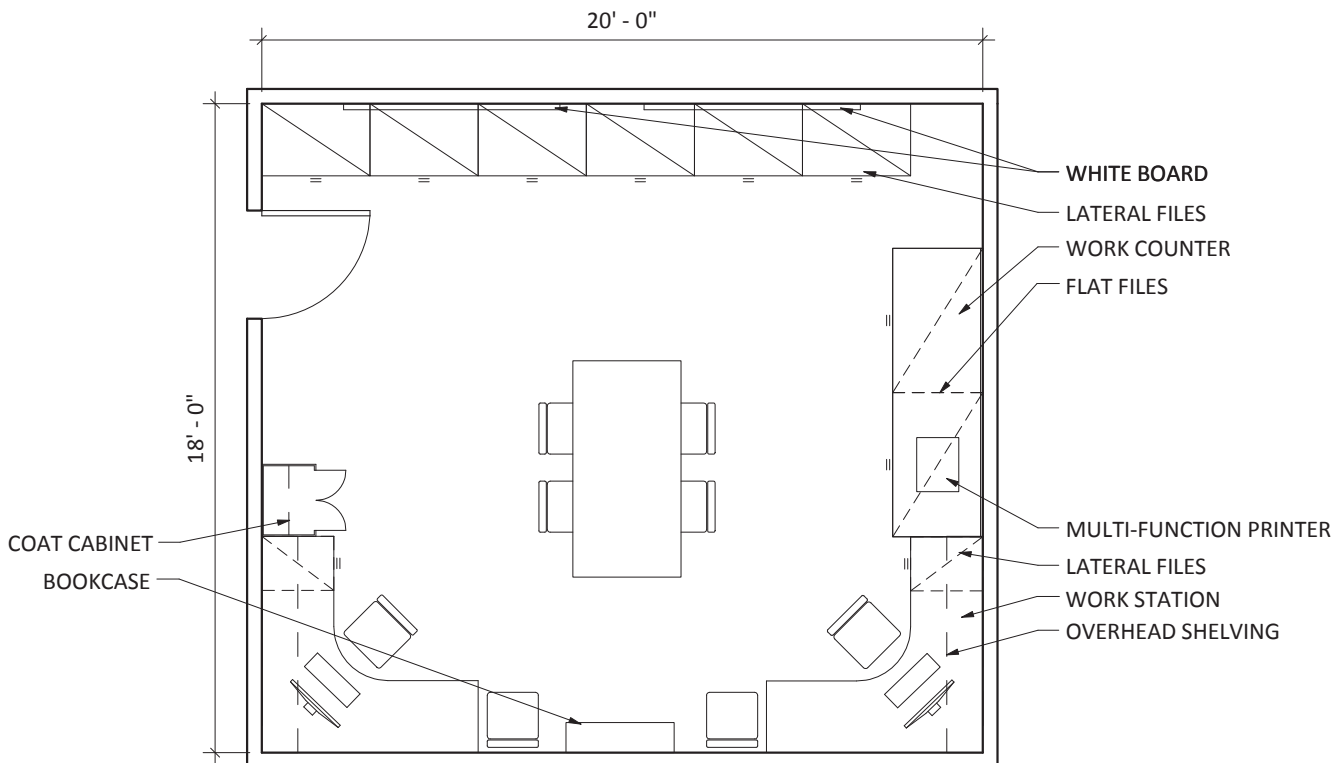

FIRE PROTECTION & TRAINING OFFICE
3/16" = 1'-0"

Donham & Sweeney
ARCHITECTS
68 Harrison Ave
Boston, MA 02111
617 - 423 - 1400

**PUBLIC SAFETY COMPLEX, SPACE NEEDS STUDY
SOUTHBOROUGH, MASSACHUSETTS**

FIRE DEPARTMENT

10.5 EMS OFFICE

Adjacency Requirement	Near Fire Chief's Office
Public Access	Minimal
Security Requirements	Moderate, controlled
Contract Millwork / Equipment	None
Floor	Carpet tile
Walls	GWB, painted
Ceiling	ACT
Lighting / Electrical	Indirect LED; CATV
HVAC / Plumbing	A/C
Special Needs	None
Owner supplied Furn. / Equip.	(2) 5'x5' work stations w/ desk & return, overhead storage bins, desk chair, guest chair, (2) 4-drawer lateral files, (1) 2-drawer lateral file with small printer / copier on top, 4' book case, coat cabinet

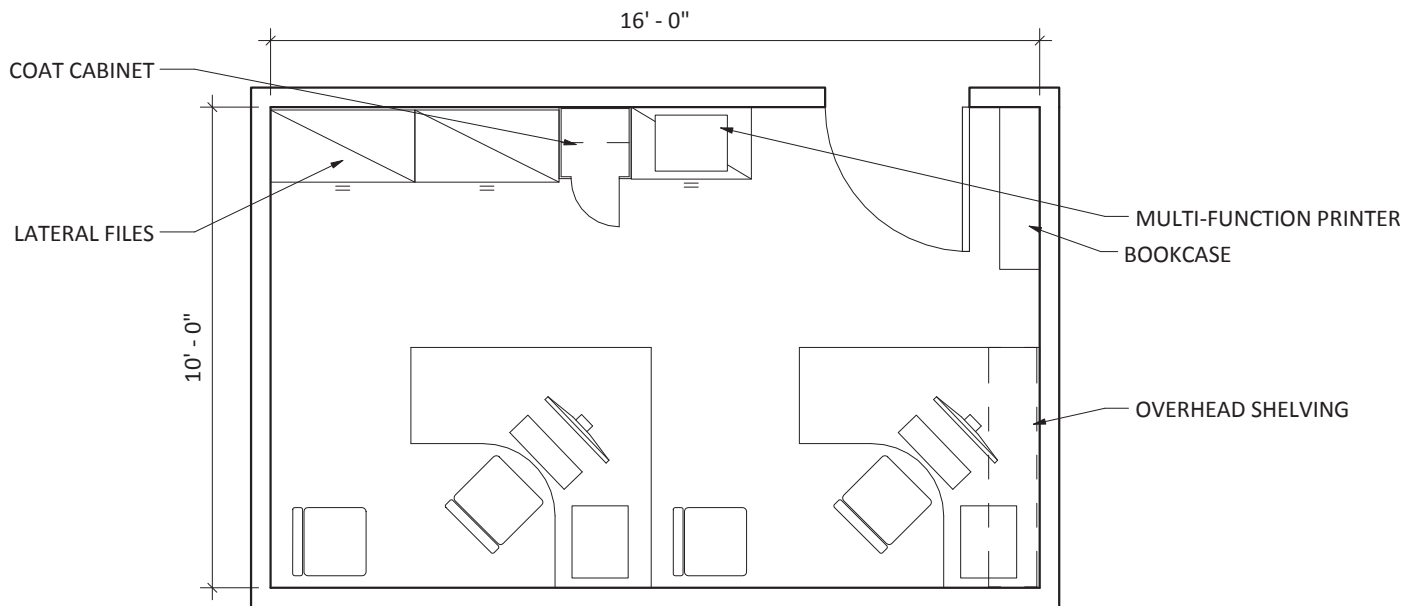

○ **EMS OFFICE**
1/4" = 1'-0"

**PUBLIC SAFETY COMPLEX, SPACE NEEDS STUDY
SOUTHBOROUGH, MASSACHUSETTS**

FIRE DEPARTMENT

10.6 ADMINISTRATIVE ASSISTANT & WAITING AREA

Adjacency Requirement	Easy Access from Public Lobby; Adjacent to Fire Prevention; Near Fire Chief & Deputy Fire Chief
Public Access	Moderate
Security Requirements	Moderate
Contract Millwork / Equipment	None
Floor	Carpet tile
Walls	GWB, painted
Ceiling	ACT
Lighting / Electrical	Indirect LED; CATV
HVAC / Plumbing	A/C
Special Needs	None
Owner supplied Furn. / Equip.	Desk w/ return; overhead storage bins, desk chair, (4) 4-drawer lateral files, printer/copier, credenza; Waiting area: (3) chairs & magazine table

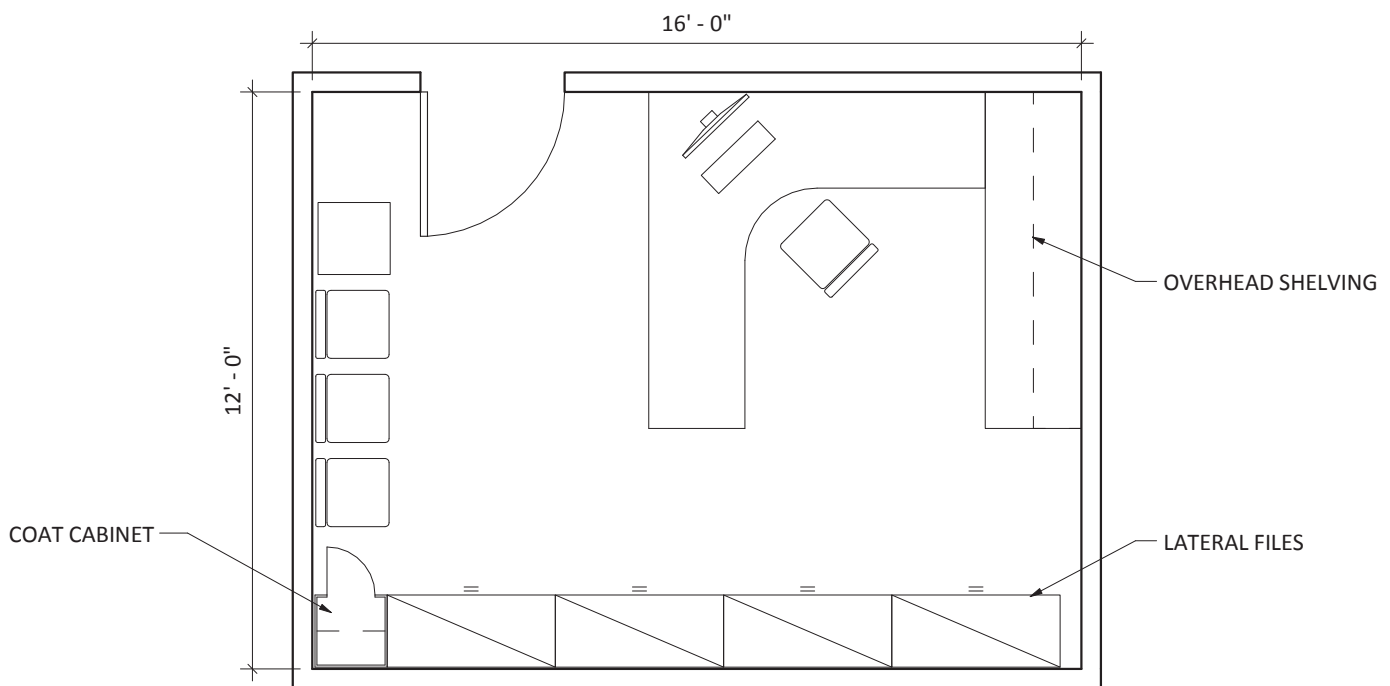

ADMINISTRATIVE ASSISTANT & WAITING AREA
1/4" = 1'-0"

**PUBLIC SAFETY COMPLEX, SPACE NEEDS STUDY
SOUTHBOROUGH, MASSACHUSETTS**

FIRE DEPARTMENT

10.7 DEAD RECORDS STORAGE

Adjacency Requirement	None
Public Access	None
Security Requirements	High
Contract Millwork / Equipment	None
Floor	Concrete w/ hardener
Walls	GWB, painted
Ceiling	ACT
Lighting / Electrical	LED
HVAC / Plumbing	A/C
Special Needs	None
Owner supplied Furn. / Equip.	Space for (20) 5-drawer high density file cabinets

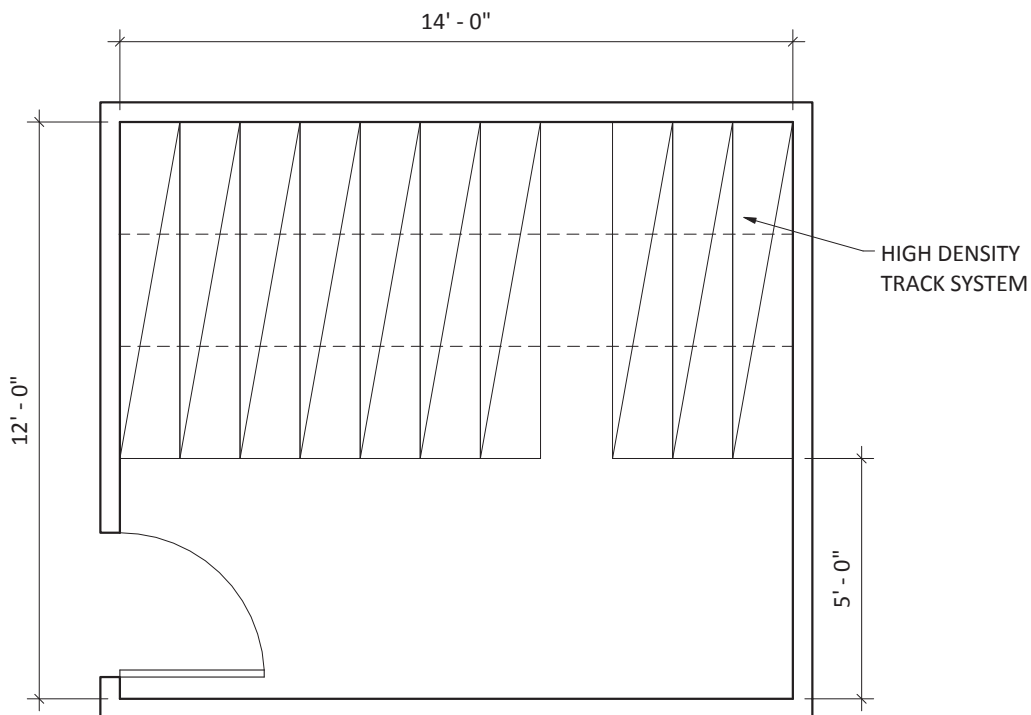

 **DEAD RECORDS STORAGE**
1/4" = 1'-0"

**PUBLIC SAFETY COMPLEX, SPACE NEEDS STUDY
SOUTHBOROUGH, MASSACHUSETTS**

FIRE DEPARTMENT

10.8 CAPTAINS OFFICE

Adjacency Requirement	Adjacent to suppression;
Public Access	Moderate
Security Requirements	High
Contract Millwork / Equipment	None
Floor	Carpet tile
Walls	GWB, painted
Ceiling	ACT
Lighting / Electrical	Indirect LED
HVAC / Plumbing	A/C
Special Needs	None
Owner supplied Furn. / Equip.	(3) workstations each w/: Desk w/ return (1) 30" 2-drawer lateral file, overhead storage bins, desk chair, (1) guest chair, Plus (6) 4-drawer lateral files, (1) 24" coat cabinet

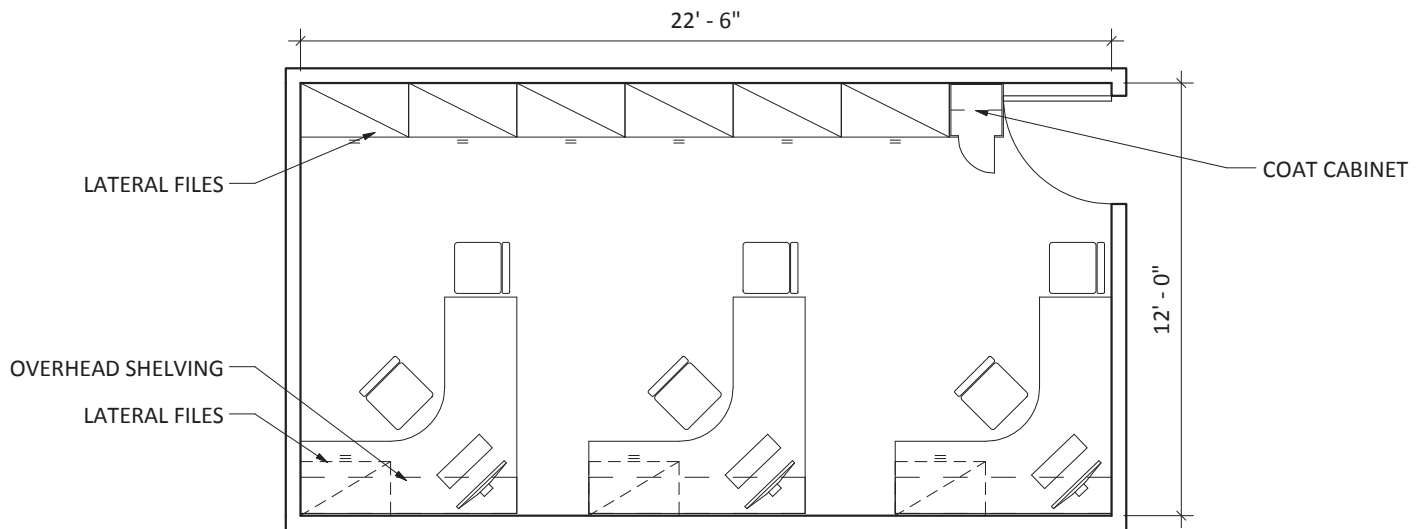

○ CAPTAINS OFFICE
3/16" = 1'-0"

**PUBLIC SAFETY COMPLEX, SPACE NEEDS STUDY
SOUTHBOROUGH, MASSACHUSETTS**

FIRE DEPARTMENT

10.9 LIEUTENANTS OFFICE

Adjacency Requirement	Adjacent to suppression
Public Access	Moderate
Security Requirements	High
Contract Millwork / Equipment	None
Floor	Carpet tile
Walls	GWB, painted
Ceiling	ACT
Lighting / Electrical	Indirect LED
HVAC / Plumbing	A/C
Special Needs	None
Owner supplied Furn. / Equip.	Desk w/ return (1) 30" 2-drawer lateral file, overhead storage bins, desk chair, (1) guest chair, (2) 4-drawer lateral files, coat cabinet

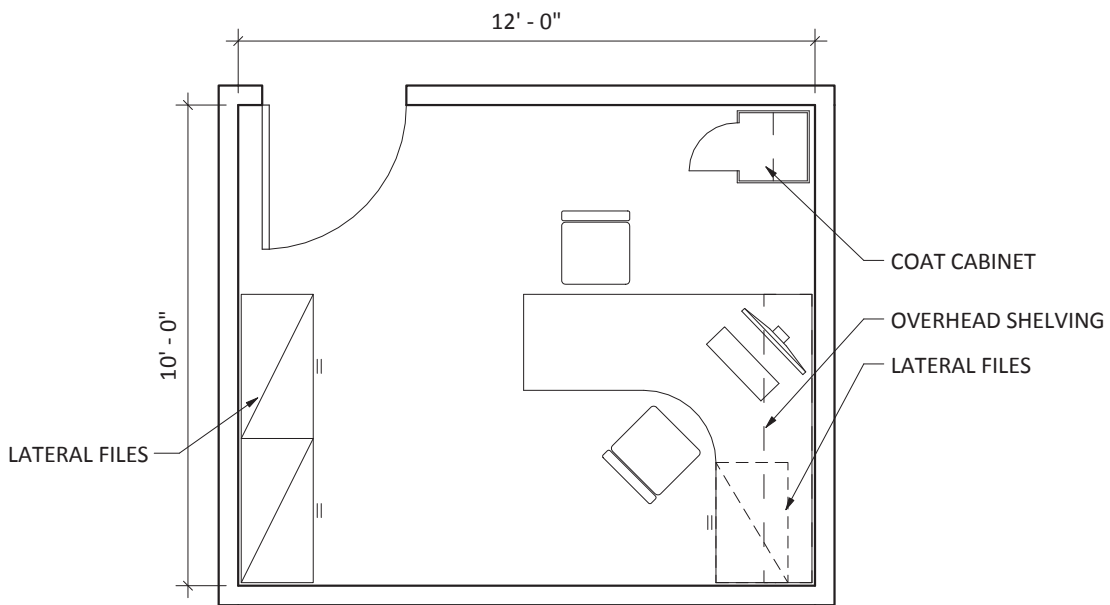

LIEUTENANTS OFFICE
1/4" = 1'-0"

**PUBLIC SAFETY COMPLEX, SPACE NEEDS STUDY
SOUTHBOROUGH, MASSACHUSETTS**

FIRE DEPARTMENT

11.1 APPARATUS ROOM

Adjacency Requirement	Good access from Firefighters' Dorm rooms, next to Support Spaces.
Public Access	Controlled via Public Lobby.
Security Requirements	Moderate
Contract Millwork / Equipment	None
Floor	Concrete w/ H.D. Floor Hardener
Walls	CMU w/ epoxy finish
Ceiling	Painted, exposed structure
Lighting / Electrical	Low Level Night Lighting, Rapid Response; Overhead power
HVAC / Plumbing	No AC; Vehicle exhaust system; overhead water fill (1 1/2" lines) at Engines; 2 compressed air lines at central locations; deluge shower; Trough floor drains
Special Needs	Overhead doors to be 14' x 14'. (5) 18' drive-through bays.
Owner supplied Furn. / Equip.	Front Line Response: Engine E22 (31'), Engine E23 (32'), Tower T21 (48'), Ambulance A28 (25'), Command C30 (19') Reserve Response: Engine (Future - 34'), Squad S24 (23'), Ambulance A29 (26'), Ambulance (future - 26'), Command C20 (16'), Command C27 (16'), Command (future - 16'), Boat on Trailer (16')

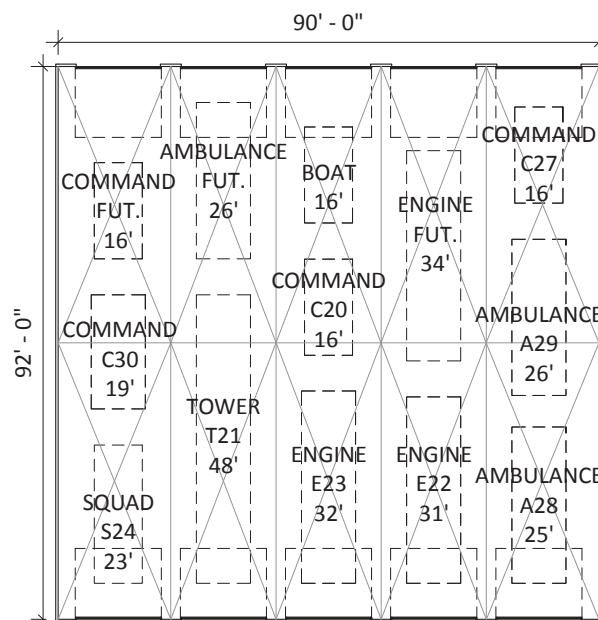

APPARATUS ROOM
1/32" = 1'-0"

Donham & Sweeney
ARCHITECTS
68 Harrison Ave
Boston, MA 02111
617 - 423 - 1400

**PUBLIC SAFETY COMPLEX, SPACE NEEDS STUDY
SOUTHBOROUGH, MASSACHUSETTS**

FIRE DEPARTMENT

11.2 TURN-OUT GEAR

Adjacency Requirement	Next to Apparatus Room
Public Access	None
Security Requirements	Moderate
Contract Millwork / Equipment	(42) steel mesh cubicles at 24" x 24" w/ top & bottom shelves, small compartment, hat hook, nameplate & door.
Floor	Concrete w/ H.D. Hardener
Walls	CMU w/ epoxy finish
Ceiling	Painted, exposed structure
Lighting / Electrical	LED; power at each locker to charge radios / lights
HVAC / Plumbing	No A/C, very good ventilation; Floor Drains
Special Needs	Metal door w/ closer; no ultraviolet light.
Owner supplied Furn. / Equip.	None

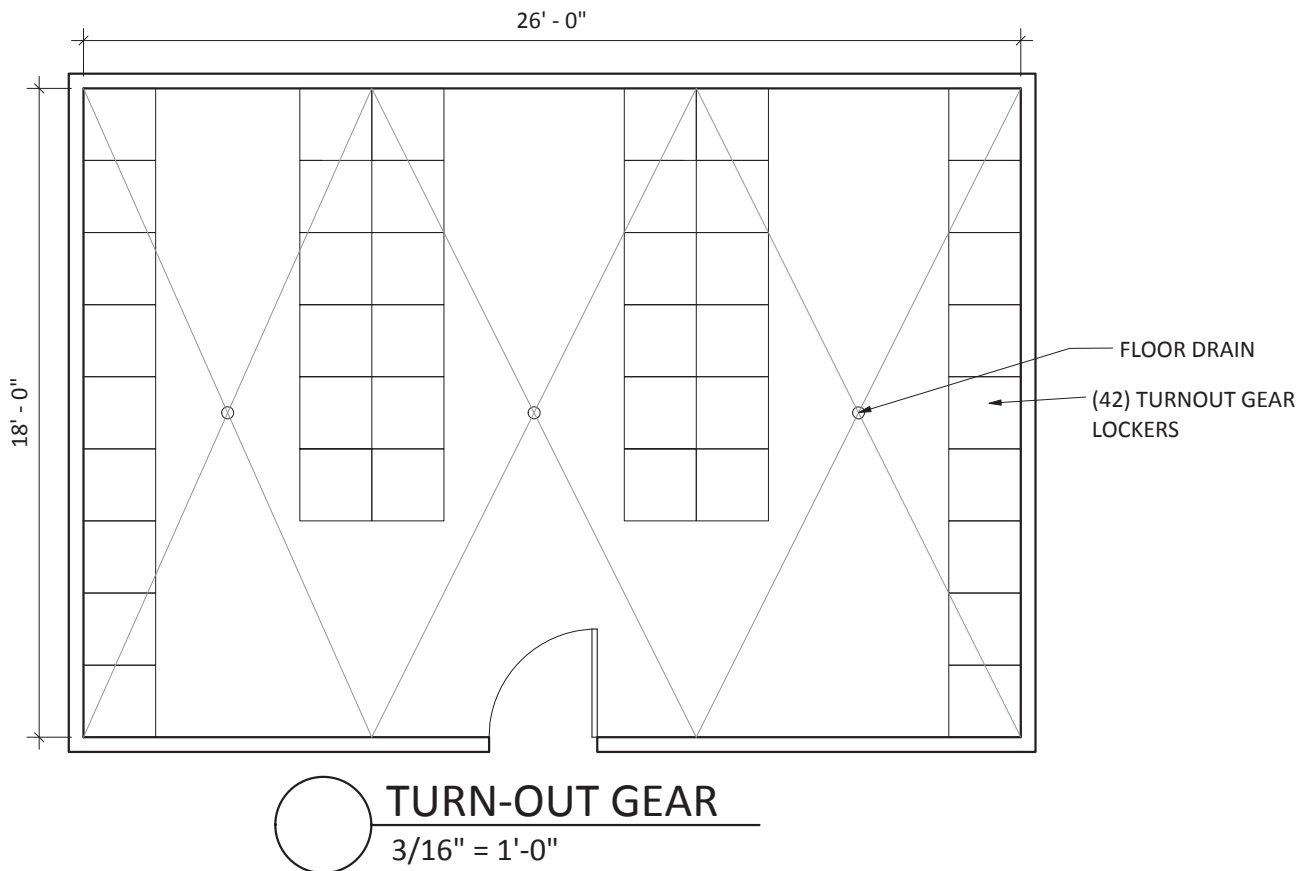

**PUBLIC SAFETY COMPLEX, SPACE NEEDS STUDY
SOUTHBOROUGH, MASSACHUSETTS**

FIRE DEPARTMENT

11.3 HOSE & FOAM STORAGE

Adjacency Requirement	Next to Apparatus Room
Public Access	None
Security Requirements	Moderate
Contract Millwork / Equipment	18" deep steel shelving 3 tiers high to hold foam
Floor	Concrete w/ H.D. hardener
Walls	CMU w/ epoxy finish
Ceiling	Painted, exposed structure
Lighting / Electrical	LED
HVAC / Plumbing	No A/C; very good ventilation; floor drains
Special Needs	No ultraviolet light; foam storage in 5 gal. buckets
Owner supplied Furn. / Equip.	Rolling hose storage racks

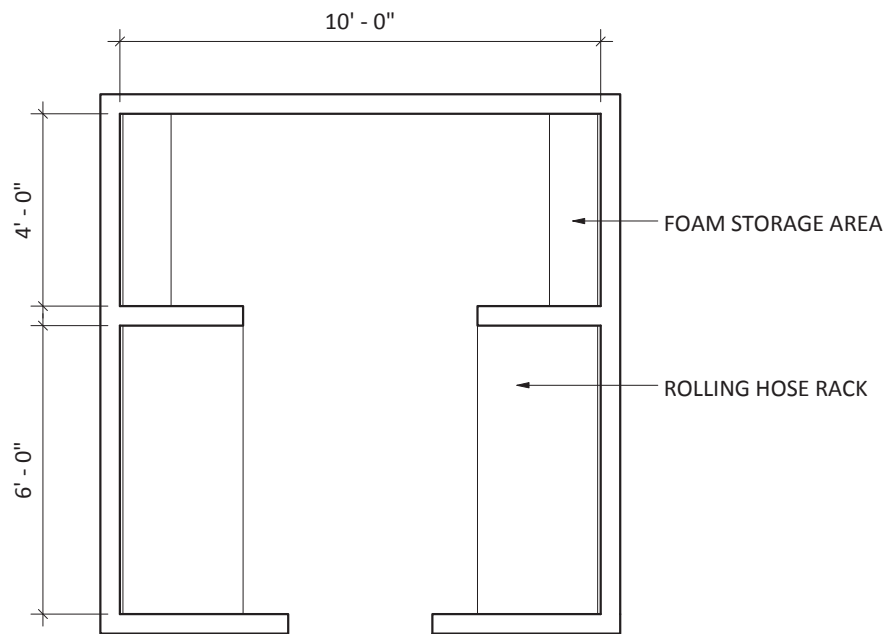

HOSE & FOAM STORAGE
1/4" = 1'-0"

**PUBLIC SAFETY COMPLEX, SPACE NEEDS STUDY
SOUTHBOROUGH, MASSACHUSETTS**

FIRE DEPARTMENT

11.4 BIOHAZARD / DECON ROOM

Adjacency Requirement	Next to Apparatus Room, near ambulance & deluge shower
Public Access	None
Security Requirements	None
Contract Millwork / Equipment	24" deep stainless steel counter, 6' long, clothes rack
Floor	Concrete w/ epoxy finish
Walls	CMU w/ epoxy finish, ceramic tile @ floor sink
Ceiling	Painted, exposed structure
Lighting / Electrical	LED
HVAC / Plumbing	No A/C; sink w/ eye wash, 3' x 5' floor sink, hose w/ overhead spray.
Special Needs	10' of garden hose w/ spray
Owner supplied Furn. / Equip.	None

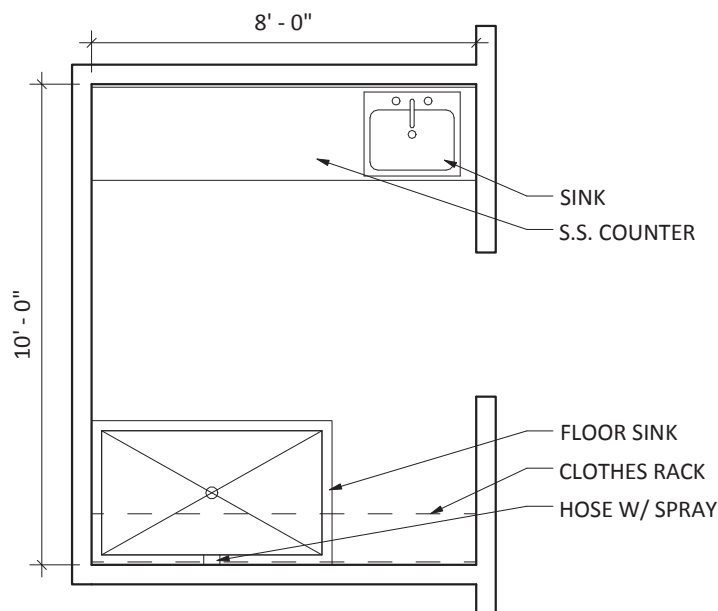

BIOHAZARD / DECON ROOM
1/4" = 1'-0"

**PUBLIC SAFETY COMPLEX, SPACE NEEDS STUDY
SOUTHBOROUGH, MASSACHUSETTS**

FIRE DEPARTMENT

11.5 EMS SUPPLIES

Adjacency Requirement	Next to Apparatus Room & ambulance
Public Access	None
Security Requirements	High
Contract Millwork / Equipment	None
Floor	Concrete w/ hardener
Walls	CMU w/ epoxy finish
Ceiling	GWB, painted
Lighting / Electrical	LED
HVAC / Plumbing	A/C, floor drain @ ice machine
Special Needs	None
Owner supplied Furn. / Equip.	(10) 18" deep x 36" steel mesh shelving units; ice machine in alcove

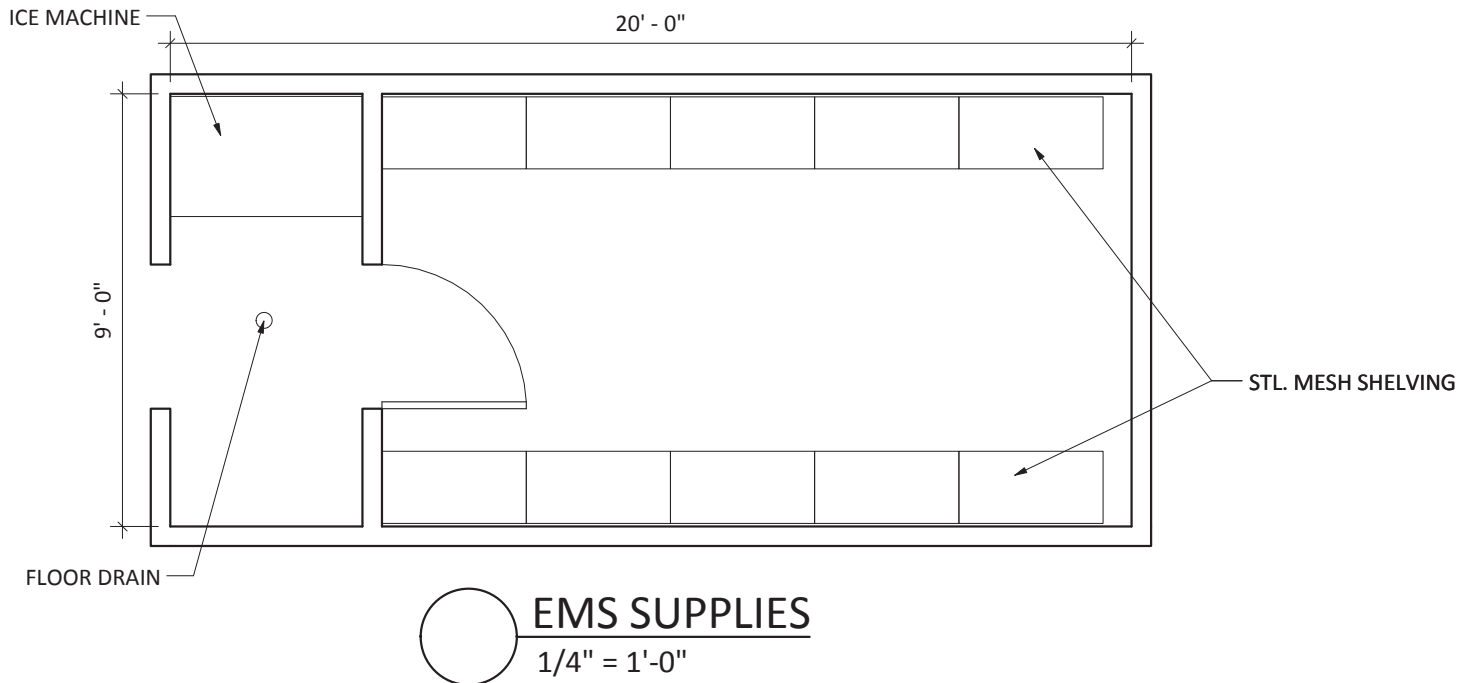

**PUBLIC SAFETY COMPLEX, SPACE NEEDS STUDY
SOUTHBOROUGH, MASSACHUSETTS**

FIRE DEPARTMENT

11.6 GEAR SUPPLY

Adjacency Requirement	Off Apparatus Room
Public Access	None
Security Requirements	Moderate
Contract Millwork / Equipment	None
Floor	Concrete w/ hardener
Walls	CMU / paint
Ceiling	Painted, exposed structure
Lighting / Electrical	LED
HVAC / Plumbing	Good exhaust
Special Needs	None
Owner supplied Furn. / Equip.	(10) 18" deep x 30" metal shelving units w/ floor space for large items. Includes storage for boots, helmets, axes, & shovels

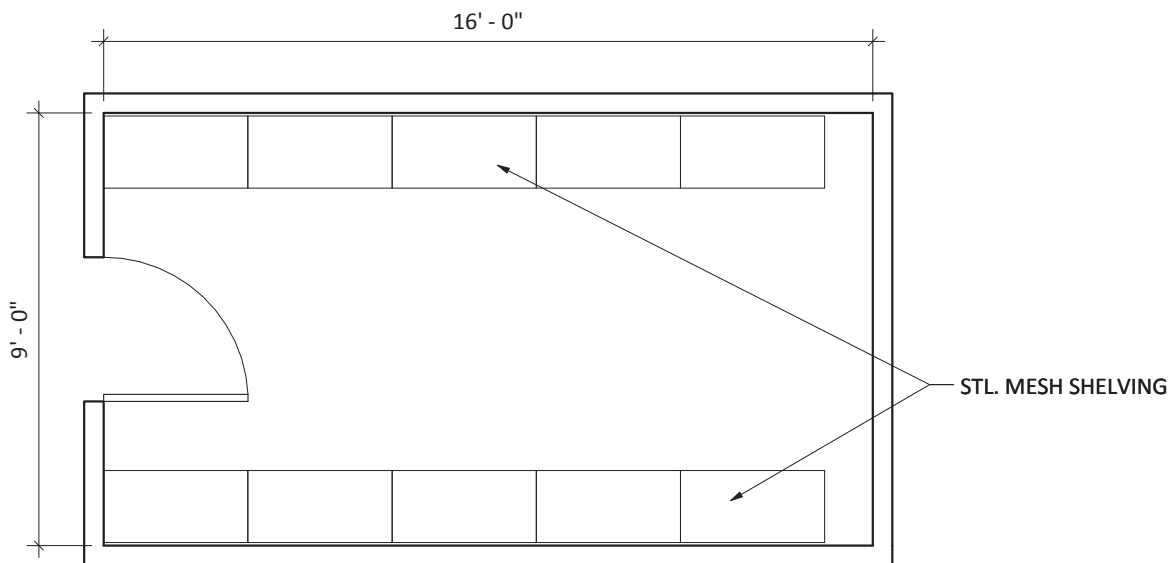

○ **GEAR SUPPLY**
1/4" = 1'-0"

**PUBLIC SAFETY COMPLEX, SPACE NEEDS STUDY
SOUTHBOROUGH, MASSACHUSETTS**

FIRE DEPARTMENT

11.7 AIR SUPPLY

Adjacency Requirement	Off Apparatus Room
Public Access	None
Security Requirements	Moderate
Contract Millwork / Equipment	2' deep standing workbench w/ shelves above
Floor	Concrete w/ epoxy finish
Walls	CMU w/ painted finish
Ceiling	GWB, painted
Lighting / Electrical	LED
HVAC / Plumbing	No A/C; good ventilation; 1" diameter pipe to clean outdoor air
Special Needs	None
Owner supplied Furn. / Equip.	Fill station (5'h x 4' long x 18" deep), compressor (5'h x 4'w x 3' deep), computer work station w/ 2-drawer lateral file cabinet

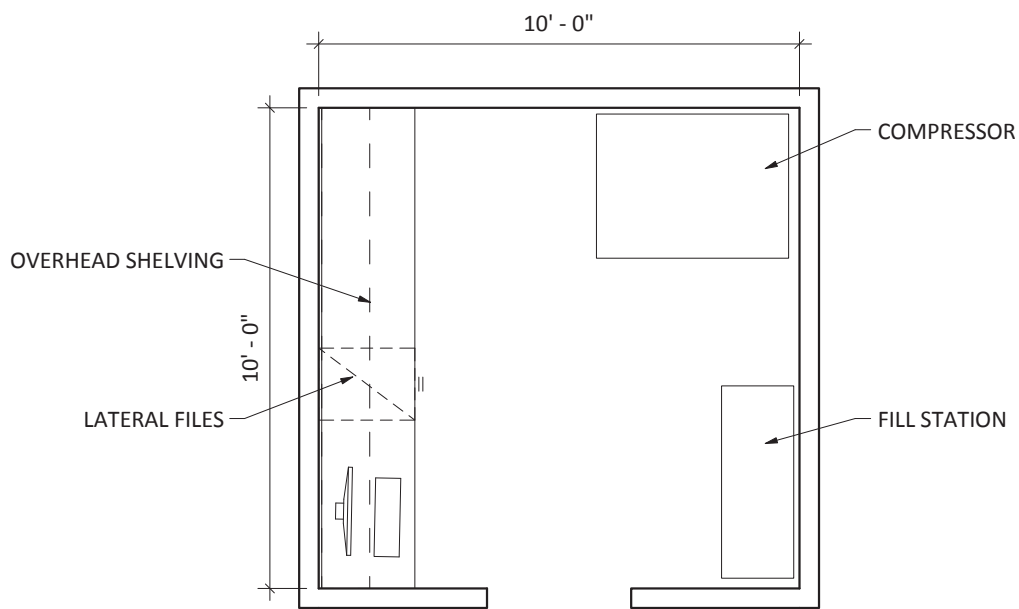

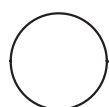
 **AIR SUPPLY**
1/4" = 1'-0"

**PUBLIC SAFETY COMPLEX, SPACE NEEDS STUDY
SOUTHBOROUGH, MASSACHUSETTS**

FIRE DEPARTMENT

11.8 WASHER / EXTRACTOR & DRYER (CONTAMINATED)

Adjacency Requirement	Off Apparatus Room, next to Turn- out Gear Room.
Public Access	None
Security Requirements	None
Contract Millwork / Equipment	None
Floor	Concrete w/ epoxy finish
Walls	CMU, painted
Ceiling	GWB, painted
Lighting / Electrical	Power for appliances & hang gear dryer
HVAC / Plumbing	No A/C, good ventilation; floor drain
Special Needs	None
Owner supplied Furn. / Equip.	Heavy duty, stainless steel, 45 lb capacity (2 1/2 sets) washer & extractor. Dryer to be gas fired. Electric hanging gear dryer for (4) sets (gloves, coat, boots, pants).

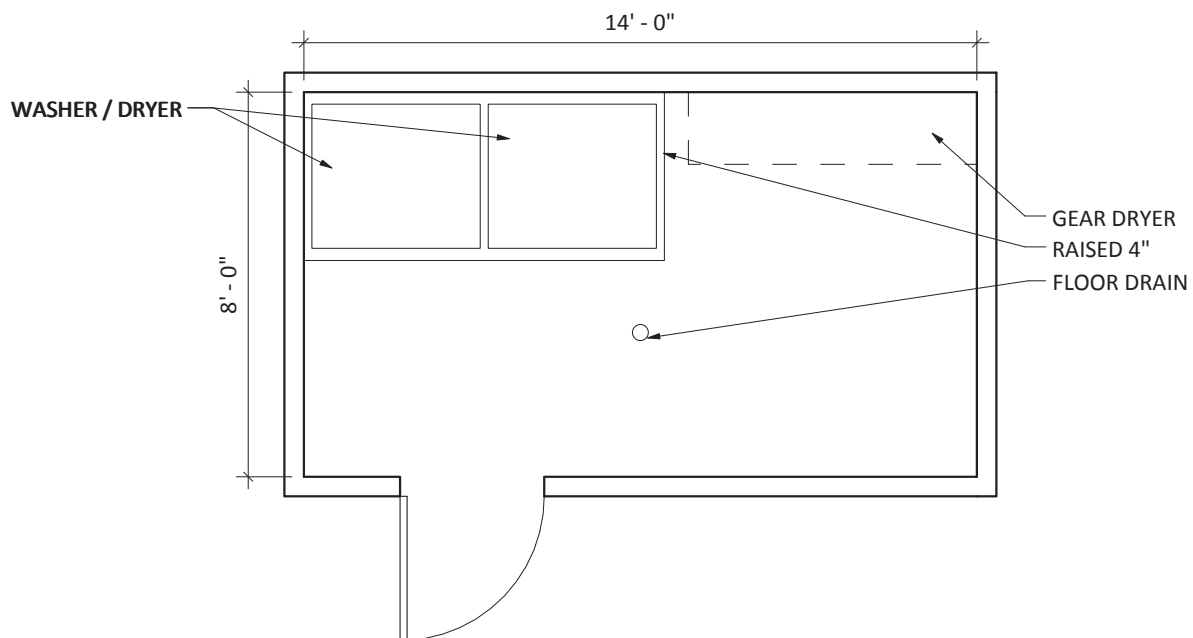

WASHER / EXTRACTOR & DRYER (CONTAMINATED)
1/4" = 1'-0"

**PUBLIC SAFETY COMPLEX, SPACE NEEDS STUDY
SOUTHBOROUGH, MASSACHUSETTS**

FIRE DEPARTMENT

11.9 TRIAGE ROOM

Adjacency Requirement	Off Apparatus Room
Public Access	None
Security Requirements	Moderate
Contract Millwork / Equipment	Counter w/ base & wall cabinets
Floor	Rubber
Walls	GWB, painted
Ceiling	ACT
Lighting / Electrical	LED
HVAC / Plumbing	A/C; sink
Special Needs	None
Owner supplied Furn. / Equip.	Computer, desk chair, guest chair

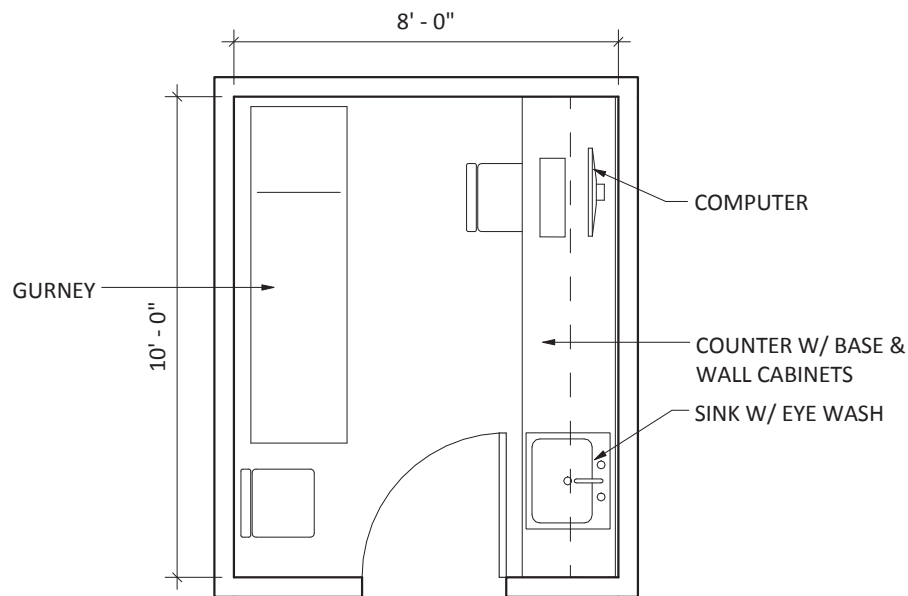

TRIAGE ROOM
1/4" = 1'-0"

**PUBLIC SAFETY COMPLEX, SPACE NEEDS STUDY
SOUTHBOROUGH, MASSACHUSETTS**

FIRE DEPARTMENT

11.10 FIREFIGHTER TOILET

Adjacency Requirement	Off Apparatus Room
Public Access	None
Security Requirements	None
Contract Millwork / Equipment	None
Floor	Ceramic tile
Walls	Ceramic wall tile
Ceiling	GWB, painted
Lighting / Electrical	LED
HVAC / Plumbing	No A/C, good ventilation; floor drain, sink, toilet
Special Needs	None
Owner supplied Furn. / Equip.	None

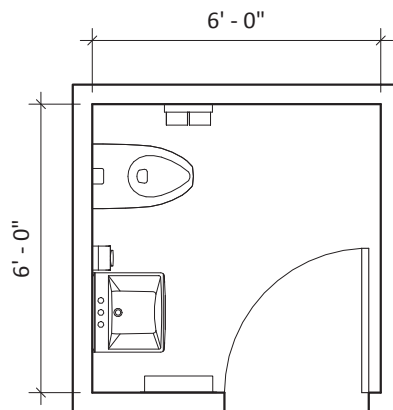

○ **FIREFIGHTER TOILET**
1/4" = 1'-0"

**PUBLIC SAFETY COMPLEX, SPACE NEEDS STUDY
SOUTHBOROUGH, MASSACHUSETTS**

FIRE DEPARTMENT

11.11 FIRE POLE

Adjacency Requirement	Off Apparatus Room & living quarters
Public Access	None
Security Requirements	None
Contract Millwork / Equipment	Tactile warning strip @ upper level
Floor	Rubber
Walls	GWB, painted
Ceiling	GWB, painted
Lighting / Electrical	LED
HVAC / Plumbing	Exhaust
Special Needs	Door w/ panic bar & gasket for fume spread
Owner supplied Furn. / Equip.	None

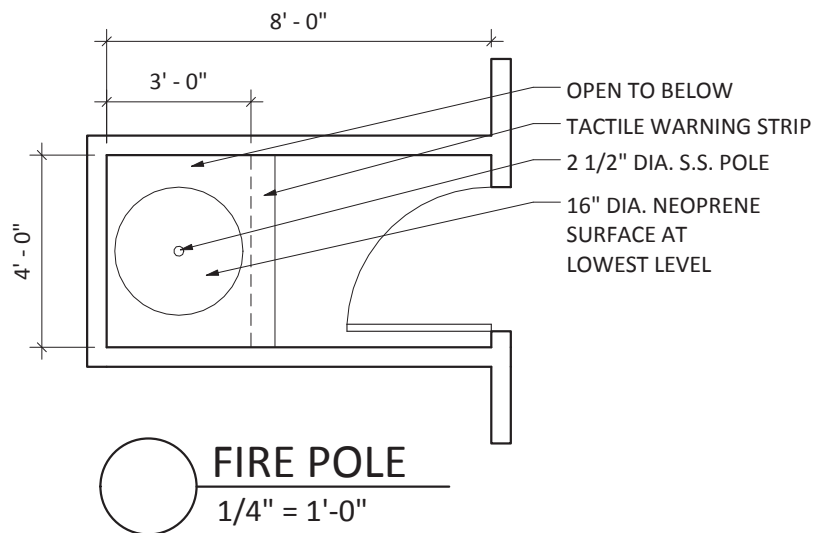

**PUBLIC SAFETY COMPLEX, SPACE NEEDS STUDY
SOUTHBOROUGH, MASSACHUSETTS**

FIRE DEPARTMENT

11.12 WATCH ROOM

Adjacency Requirement	Next to Apparatus Room & firefighters entrance w/ view to apron
Public Access	Limited
Security Requirements	Moderate
Contract Millwork / Equipment	Work counter w/ solid surface top, white board
Floor	Rubber
Walls	CMU
Ceiling	ACT
Lighting / Electrical	LED, multiple power outlets
HVAC / Plumbing	A/C
Special Needs	None
Owner supplied Furn. / Equip.	desk chair, zetron console, multifunction printer, bookcase

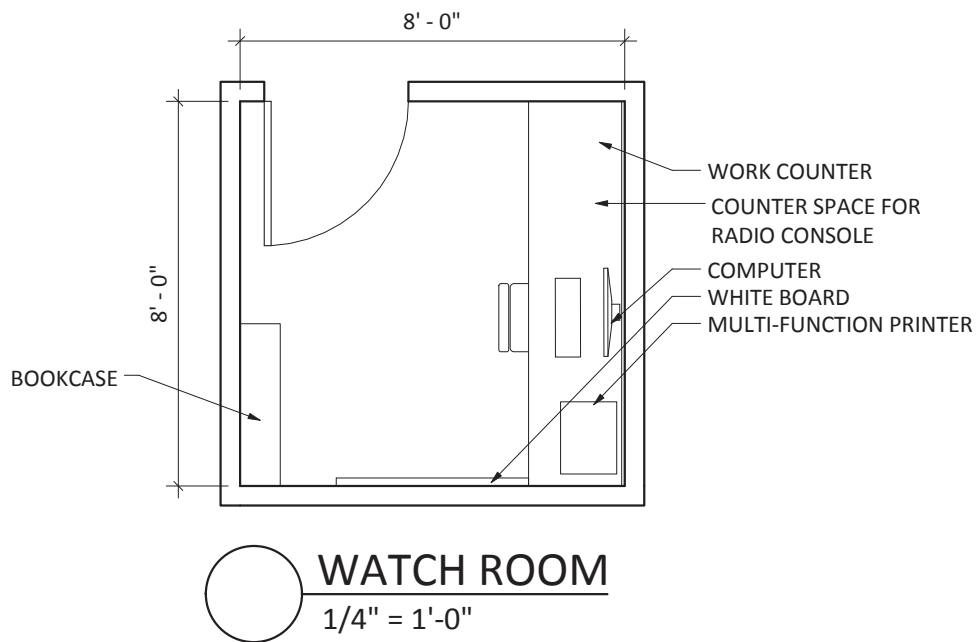

**PUBLIC SAFETY COMPLEX, SPACE NEEDS STUDY
SOUTHBOROUGH, MASSACHUSETTS**

FIRE DEPARTMENT

11.13 EQUIPMENT REPAIR

Adjacency Requirement	Off Apparatus
Public Access	None
Security Requirements	Low
Contract Millwork / Equipment	(2) 8' workbenches
Floor	Concrete w/ hardener
Walls	CMU w/ painted finish
Ceiling	Exposed, painted
Lighting/ Electrical	LED on sensor; power for welder
HVAC/ Plumbing	Exhaust, compressed air
Special Needs	Welding station
Owner supplied Furn. / Equip.	Welding equipment, tools, vises, (2) stools, shelving

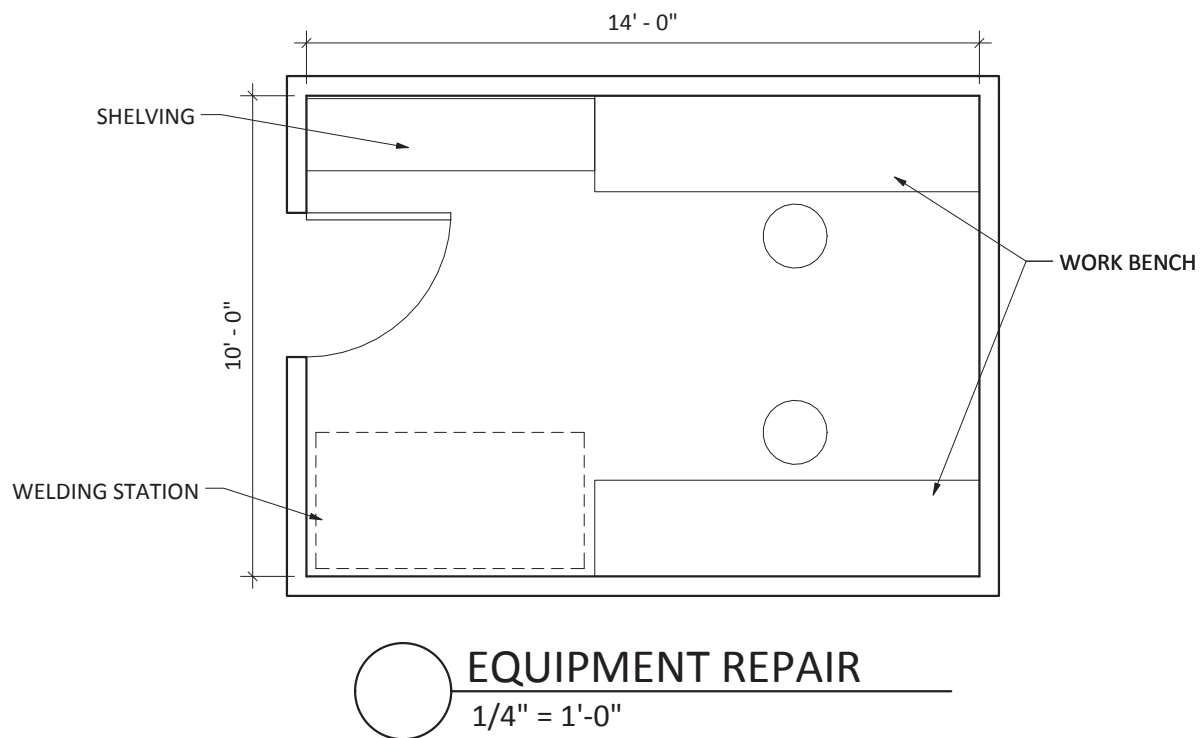

**PUBLIC SAFETY COMPLEX, SPACE NEEDS STUDY
SOUTHBOROUGH, MASSACHUSETTS**

FIRE DEPARTMENT

11.14 "SAFE" PROGRAM STORAGE

Adjacency Requirement	Off Apparatus
Public Access	None
Security Requirements	Locked
Contract Millwork / Equipment	18" Deep metal storage shelving on one wall
Floor	Concrete w/ hardener
Walls	CMU w/ painted finish
Ceiling	Exposed, painted
Lighting/ Electrical	LED on sensor
HVAC/ Plumbing	Exhaust
Special Needs	None
Owner supplied Furn. / Equip.	None

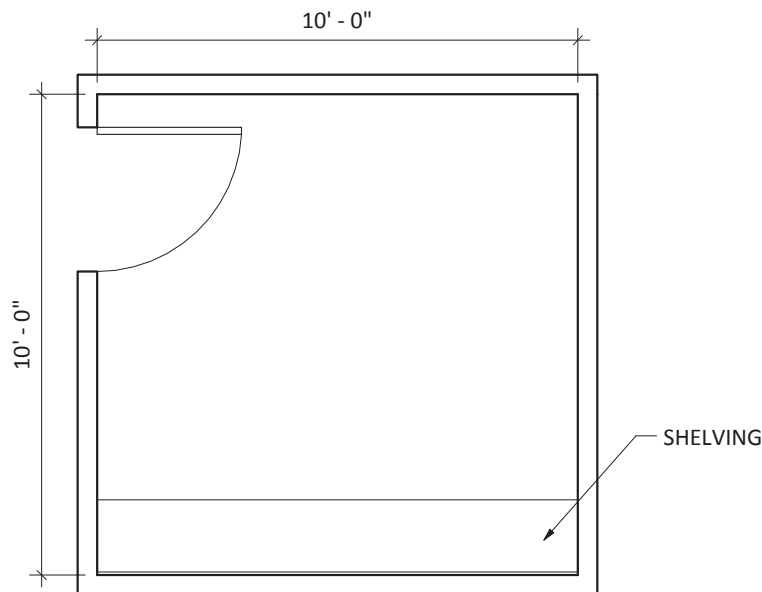

○ "SAFE" PROGRAM STORAGE
1/4" = 1'-0"

**PUBLIC SAFETY COMPLEX, SPACE NEEDS STUDY
SOUTHBOROUGH, MASSACHUSETTS**

FIRE DEPARTMENT

11.15 EMERGENCY MANAGEMENT STORAGE

Adjacency Requirement	Exterior Access
Public Access	None
Security Requirements	Moderate
Contract Millwork / Equipment	15" deep shelves on 1 wall
Floor	Concrete w/ hardener
Walls	CMU w/ epoxy paint
Ceiling	Exposed, painted
Lighting / Electrical	LED w/ sensor
HVAC / Plumbing	Exhaust
Special Needs	None
Owner supplied Furn. / Equip.	(5) 3' Metal cabinets, (4) 4-drawer lateral file cabinets, Storage of: (8) folding tables, (6) folding chairs

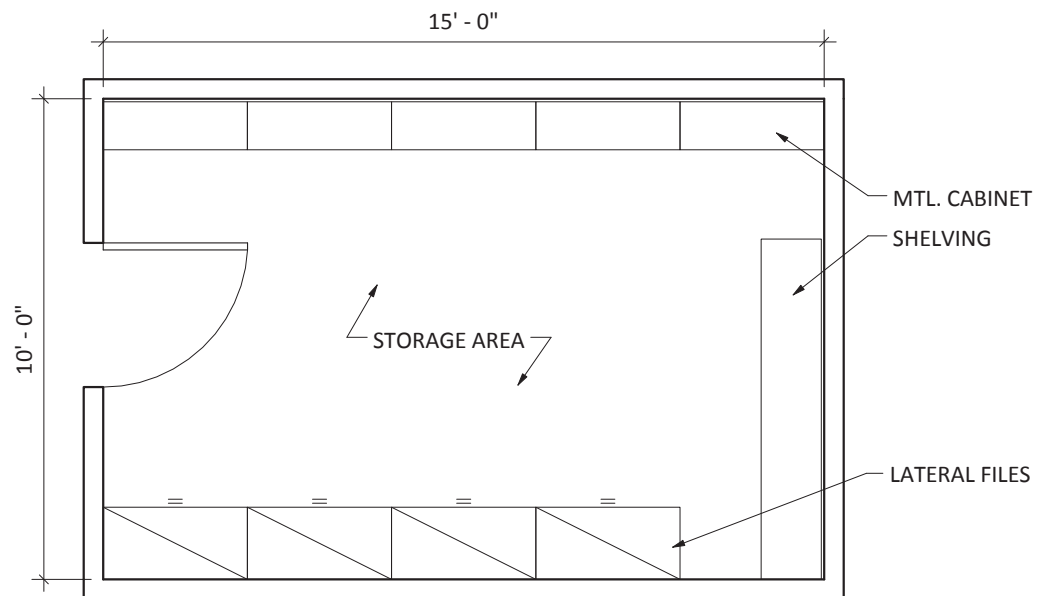

EMERGENCY MANAGEMENT STORAGE
1/4" = 1'-0"

**PUBLIC SAFETY COMPLEX, SPACE NEEDS STUDY
SOUTHBOROUGH, MASSACHUSETTS**

FIRE DEPARTMENT

12.1 KITCHEN

Adjacency Requirement	Near Firefighter Dorm; near Dining & Day Room, Near Training Room/EOC
Public Access	None
Security Requirements	Moderate
Contract Millwork / Equipment	S.S. countertops w/ base cabinets & shelving above, (4) lockable food cabinets, shared food pantry, work areas for food prep and serving. Commercial appliances; 6-burner range w/ (2) ovens, flattop griddle, exhaust hood w/ Ansul, countertop loading dishwasher, (2) 30" wide refrigerator/freezers,
Floor	Quarry tile, or epoxy
Walls	GWB, painted
Ceiling	ACT
Lighting / Electrical	LED; CATV
HVAC / Plumbing	A/C; 3-bowl sink, grease trap
Special Needs	Commercial Kitchen; Must be set up to serve large amounts of people, Training Room/EOC
Owner supplied Furn. / Equip.	Microwave, coffee maker

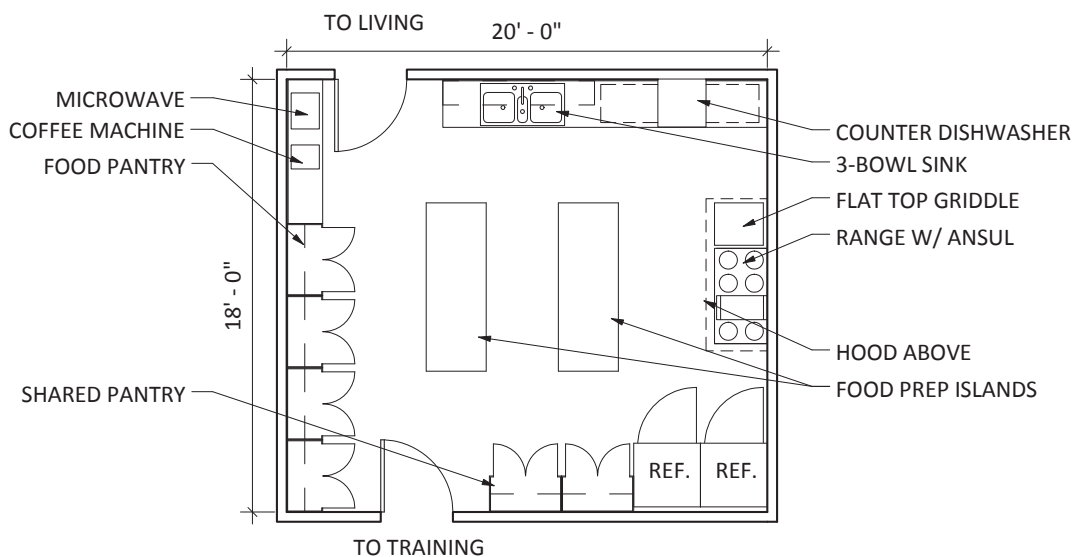

KITCHEN
1/8" = 1'-0"

**PUBLIC SAFETY COMPLEX, SPACE NEEDS STUDY
SOUTHBOROUGH, MASSACHUSETTS**

FIRE DEPARTMENT

12.2 DAY & DINING ROOM

Adjacency Requirement	Near Firefighter Dorm Rooms; next to Kitchen
Public Access	None
Security Requirements	Moderate
Contract Millwork / Equipment	None
Floor	Linoleum
Walls	GWB, painted w/ chair rail
Ceiling	ACT
Lighting / Electrical	Indirect LED, dimmable; CATV
HVAC / Plumbing	A/C
Special Needs	None
Owner supplied Furn. / Equip.	(8) recliners, flat screen TV, end tables, coffee table, task lighting, cabinet for cable box & Blue-Ray player below TV. (1) 3'x10' dining table w/ (10) chairs

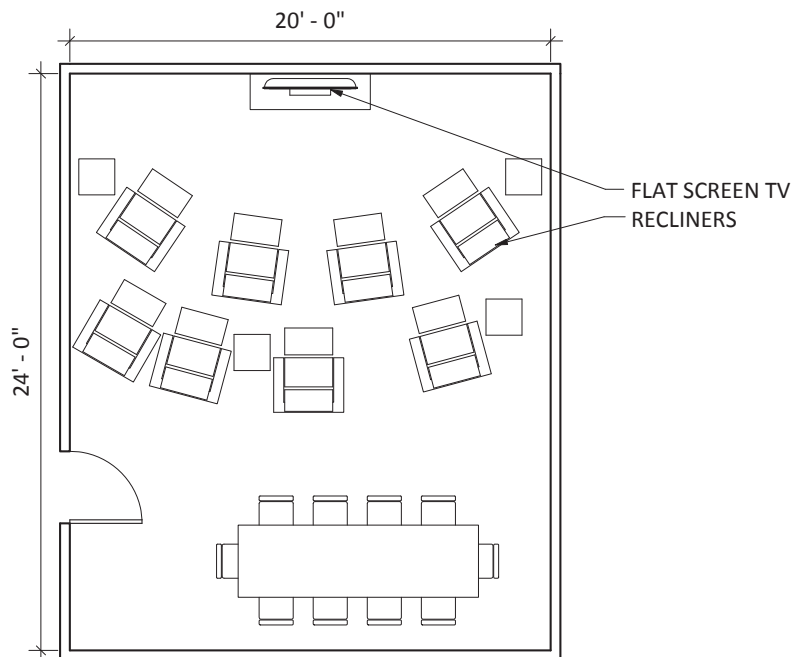

DAY / DINING ROOM
1/8" = 1'-0"

**PUBLIC SAFETY COMPLEX, SPACE NEEDS STUDY
SOUTHBOROUGH, MASSACHUSETTS**

FIRE DEPARTMENT

12.3 MEN'S SHOWERS

Adjacency Requirement	Near Firefighter Dorm Rooms
Public Access	None
Security Requirements	Privacy
Contract Millwork / Equipment	Solid Surface Counter
Floor	Ceramic tile
Walls	GWB, ceramic tile wainscot typ., full height at showers
Ceiling	GWB, painted
Lighting / Electrical	LED w/ sensor
HVAC / Plumbing	A/C; exhaust; (2) showers w/ drying areas, (2) toilets, (2) urinals, (2) sinks
Special Needs	Continuous mirrors above counter; handicap accessible.
Owner supplied Furn. / Equip.	None

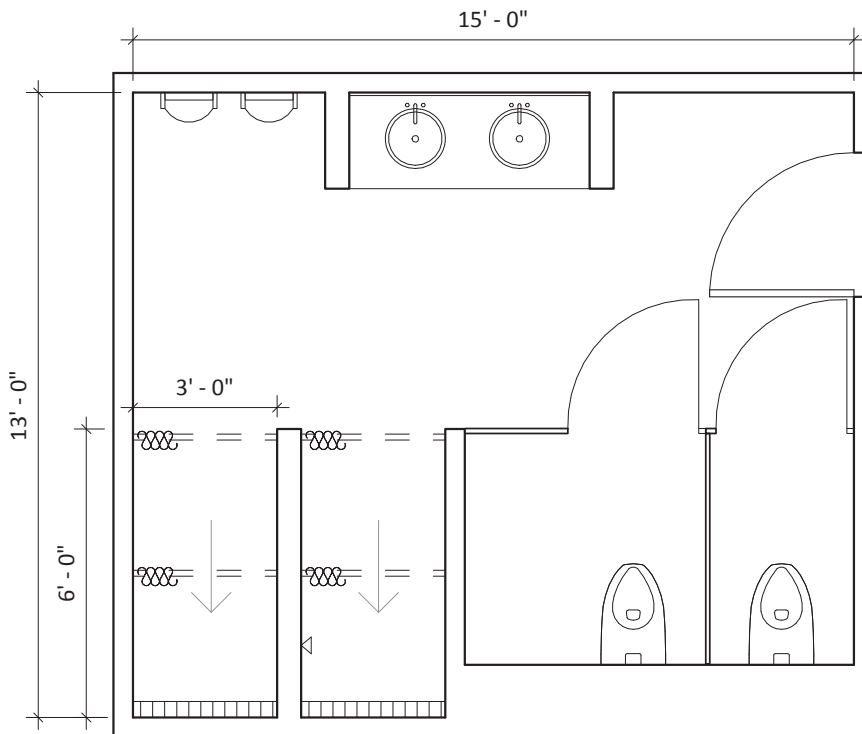

○ **MEN'S SHOWERS**
1/4" = 1'-0"

**PUBLIC SAFETY COMPLEX, SPACE NEEDS STUDY
SOUTHBOROUGH, MASSACHUSETTS**

FIRE DEPARTMENT

12.4 WOMEN'S SHOWER

Adjacency Requirement	Near Firefighter Dorm Rooms
Public Access	None
Security Requirements	Privacy
Contract Millwork / Equipment	Solid Surface Counter
Floor	Ceramic tile
Walls	GWB, ceramic tile wainscot typ., full height at showers
Ceiling	GWB, painted
Lighting / Electrical	LED w/ sensor
HVAC / Plumbing	A/C; exhaust; (1) shower w/ drying area, (1) toilet, (1) sink
Special Needs	Continuous mirrors above counter; full length mirror; handicap accessible.
Owner supplied Furn. / Equip.	None

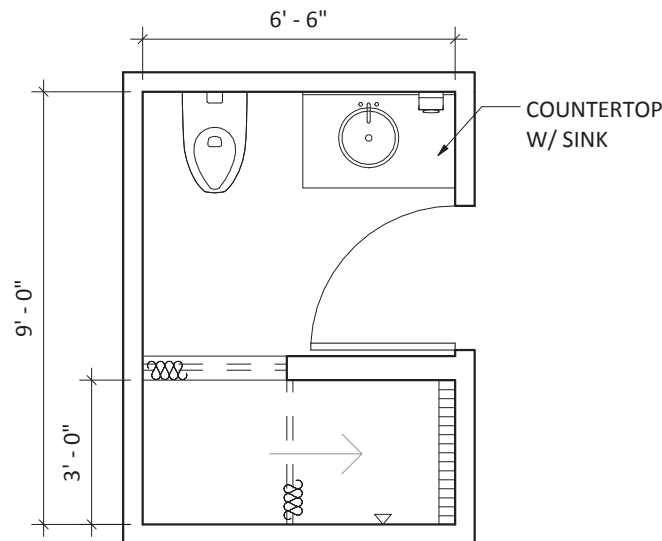

○ **WOMEN'S SHOWER**
1/4" = 1'-0"

**PUBLIC SAFETY COMPLEX, SPACE NEEDS STUDY
SOUTHBOROUGH, MASSACHUSETTS**

FIRE DEPARTMENT

12.5 FIREFIGHTER DORM ROOMS

Adjacency Requirement	Easy access to Apparatus Room
Public Access	None
Security Requirements	Minimum
Contract Millwork / Equipment	(4) 36"W x 24"D wardrobe lockers
Floor	Carpet tile
Walls	GWB w/ sound insulation
Ceiling	ACT
Lighting / Electrical	LED - 2 levels; data/ telephone jacks
HVAC / Plumbing	A/C
Special Needs	None
Owner supplied Furn. / Equip.	Bed, night table, chair, space for fold out cot, desk & chair

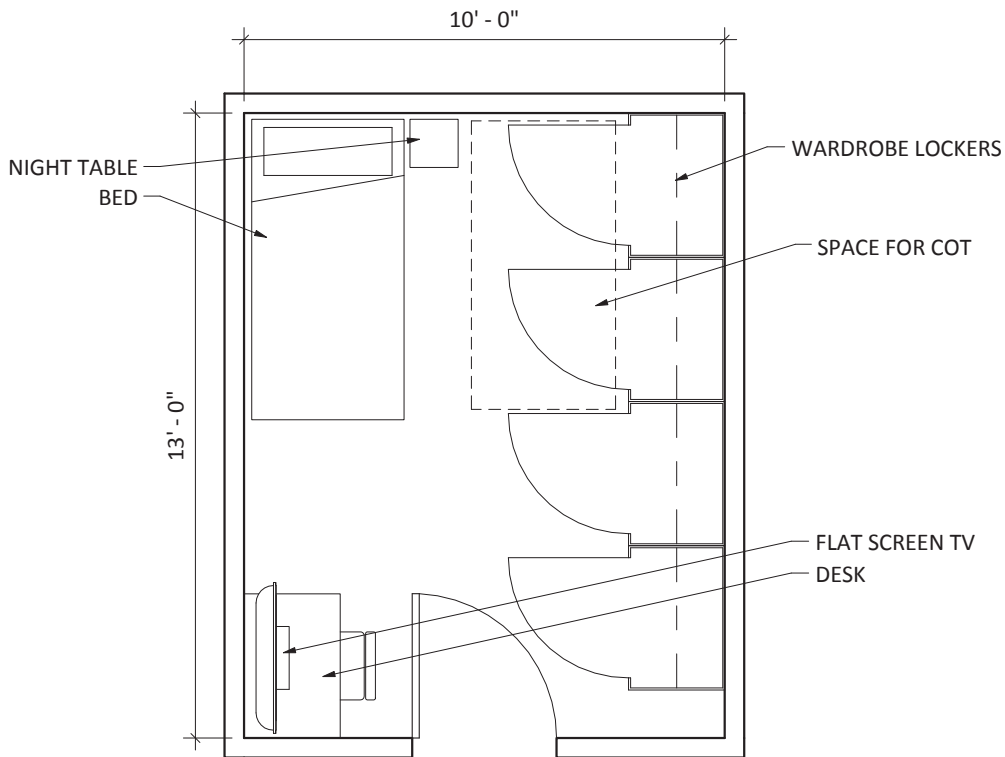

FIREFIGHTER DORM ROOMS
1/4" = 1'-0"

**PUBLIC SAFETY COMPLEX, SPACE NEEDS STUDY
SOUTHBOROUGH, MASSACHUSETTS**

FIRE DEPARTMENT

12.6 STUDY

Adjacency Requirement	Private and quiet, away from Day Room
Public Access	None
Security Requirements	Moderate
Contract Millwork / Equipment	Workcounter, 20LF book shelving
Floor	Carpet tile
Walls	GWB, sound insulation w/ chair rail
Ceiling	ACT
Lighting / Electrical	LED w/ sensor
HVAC / Plumbing	A/C
Special Needs	None
Owner supplied Furn. / Equip.	(2) work stations, (2) chairs, 3' round table w/ (2) chairs

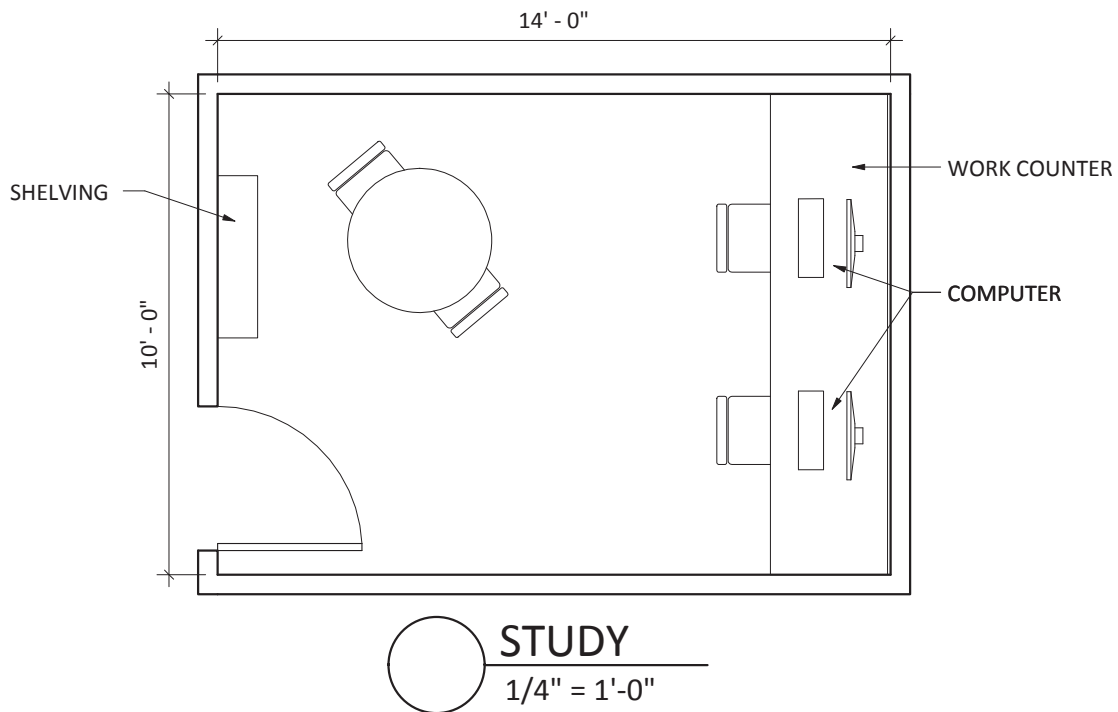

**PUBLIC SAFETY COMPLEX, SPACE NEEDS STUDY
SOUTHBOROUGH, MASSACHUSETTS**

FIRE DEPARTMENT

12.7 WASHER / DRYER

Adjacency Requirement	Located on same floor as Firefighter Dorm Rooms
Public Access	None
Security Requirements	Minimum
Contract Millwork / Equipment	12" Shelf, Washer & Dryer
Floor	Linoleum
Walls	GWB, painted
Ceiling	ACT
Lighting / Electrical	LED - Power for appliances
HVAC / Plumbing	Exhaust vent & gas for dryer
Special Needs	None
Owner supplied Furn. / Equip.	None

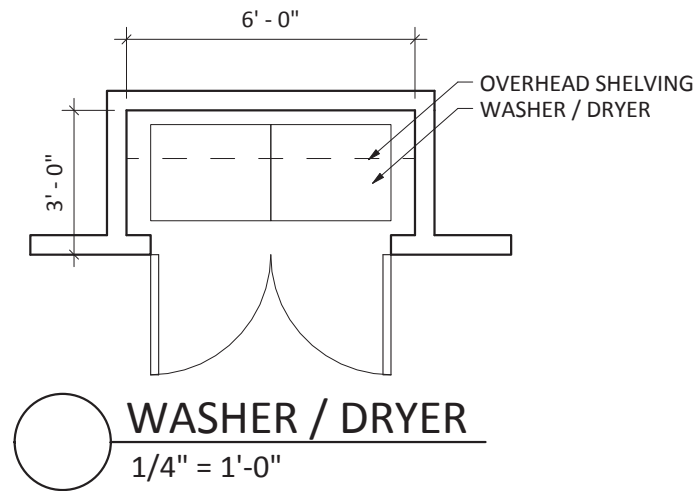

**PUBLIC SAFETY COMPLEX, SPACE NEEDS STUDY
SOUTHBOROUGH, MASSACHUSETTS**

FIRE DEPARTMENT

12.8 STORAGE & SUPPLIES

Adjacency Requirement	Near Firefighters Quarters & Kitchen
Public Access	None
Security Requirements	Moderate
Contract Millwork / Equipment	15" deep shelves on (3) walls
Floor	Linoleum
Walls	GWB
Ceiling	ACT
Lighting / Electrical	LED w/ sensor
HVAC / Plumbing	Ventilation
Special Needs	None
Owner supplied Furn. / Equip.	None

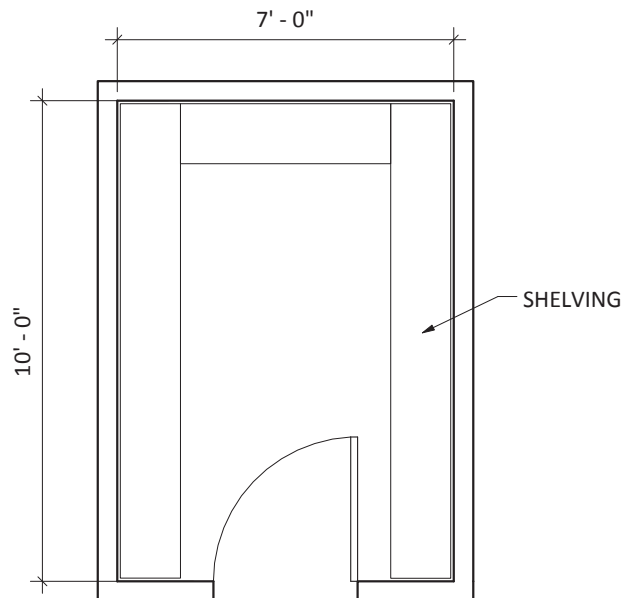

○ STORAGE & SUPPLIES
1/4" = 1'-0"

**PUBLIC SAFETY COMPLEX, SPACE NEEDS STUDY
SOUTHBOROUGH, MASSACHUSETTS**

FIRE DEPARTMENT

13.1 TRAINING STAIR/TOWER

Adjacency Requirement	Exterior Access
Public Access	None
Security Requirements	Lockable
Contract Millwork / Equipment	None
Floor	Concrete w/ hardener
Walls	CMU, unpainted
Ceiling	Exposed, galvanized, unpainted
Lighting / Electrical	LED w/ sensor
HVAC / Plumbing	Separate dry sprinkler system, large floor drain at lowest level
Special Needs	Rugged construction to withstand training, access window with 270 deg hinge at top
Owner supplied Furn. / Equip.	None

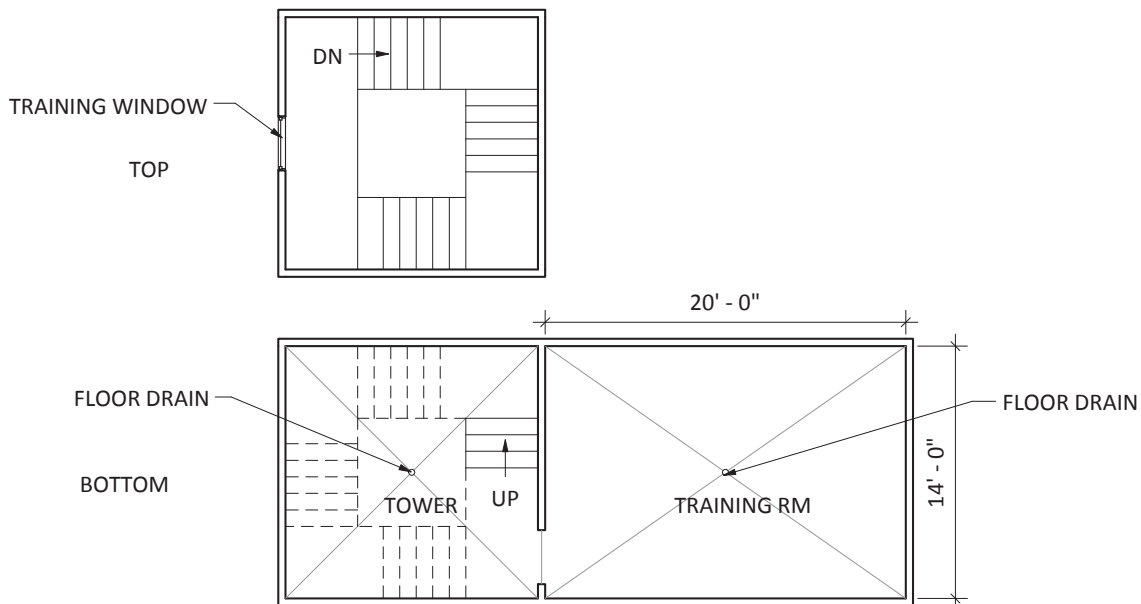

TRAINING STAIR / TOWER
3/32" = 1'-0"

END OF DOCUMENT